



ADVANCED INFORMATION
KH29LV160D T/B

16M-BIT [2M x 8 / 1M x 16] 3V SUPPLY FLASH MEMORY

KH29LV160D T/B
DATASHEET



Contents

FEATURES	5
GENERAL DESCRIPTION	6
PIN CONFIGURATIONS	7
PIN DESCRIPTION	7
BLOCK DIAGRAM	8
BLOCK DIAGRAM DESCRIPTION	9
BLOCK STRUCTURE	10
Table 1-1. KH29LV160DT SECTOR ARCHITECTURE	10
Table 1-2. KH29LV160DB SECTOR ARCHITECTURE	11
BUS OPERATION	12
Table 2-1. BUS OPERATION	12
Table 2-2. BUS OPERATION	13
FUNCTIONAL OPERATION DESCRIPTION	14
WRITE COMMANDS/COMMAND SEQUENCES	14
REQUIREMENTS FOR READING ARRAY DATA	14
RESET# OPERATION	15
SECTOR PROTECT OPERATION	15
CHIP UNPROTECT OPERATION	15
HARDWARE WRITE PROTECT	15
ACCELERATED PROGRAMMING OPERATION	15
TEMPORARY SECTOR UNPROTECT OPERATION	16
AUTOMATIC SELECT OPERATION	16
VERIFY SECTOR PROTECT STATUS OPERATION	16
DATA PROTECTION	16
LOW VCC WRITE INHIBIT	16
WRITE PULSE "GLITCH" PROTECTION	16
LOGICAL INHIBIT	17
POWER-UP SEQUENCE	17
POWER-UP WRITE INHIBIT	17
POWER SUPPLY DECOUPLING	17
COMMAND OPERATIONS	18
TABLE 3. KH29LV160D T/B COMMAND DEFINITIONS	18
AUTOMATIC PROGRAMMING OF THE MEMORY ARRAY	19



ADVANCED INFORMATION

KH29LV160D T/B

ERASING THE MEMORY ARRAY	19
SECTOR ERASE	20
SECTOR ERASE SUSPEND	21
CHIP ERASE	21
AUTOMATIC SELECT COMMAND SEQUENCE	22
SECTOR ERASE RESUME	22
AUTOMATIC SELECT OPERATIONS	22
READ MANUFACTURER ID OR DEVICE ID	23
VERIFY SECTOR GROUP PROTECTION	23
RESET	23
COMMON FLASH MEMORY INTERFACE (CFI) MODE	24
QUERY COMMAND AND COMMON FLASH INTERFACE (CFI) MODE	24
Table 4-1. CFI mode: Identification Data Values	24
Table 4-2. CFI Mode: System Interface Data Values	24
Table 4-3. CFI Mode: Device Geometry Data Values	25
Table 4-4. CFI Mode: Primary Vendor-Specific Extended Query Data Values	26
ELECTRICAL CHARACTERISTICS	27
OPERATING TEMPERATURE AND VOLTAGE	27
ABSOLUTE MAXIMUM STRESS RATINGS	27
DC CHARACTERISTICS	28
SWITCHING TEST WAVEFORM	29
SWITCHING TEST CIRCUIT	29
AC CHARACTERISTICS	30
WRITE COMMAND OPERATION	31
Figure 1. COMMAND WRITE OPERATION	31
READ/RESET OPERATION	32
Figure 2. READ TIMING WAVEFORM	32
Figure 3. RESET# TIMING WAVEFORM	33
ERASE/PROGRAM OPERATION	34
Figure 4. AUTOMATIC CHIP ERASE TIMING WAVEFORM	34
Figure 5. AUTOMATIC CHIP ERASE ALGORITHM FLOWCHART	35
Figure 6. AUTOMATIC SECTOR ERASE TIMING WAVEFORM	36
Figure 7. AUTOMATIC SECTOR ERASE ALGORITHM FLOWCHART	37
Figure 8. ERASE SUSPEND/RESUME FLOWCHART	38
Figure 9. AUTOMATIC PROGRAM TIMING WAVEFORM	39
Figure 10. ACCELERATED PROGRAM TIMING DIAGRAM	39
Figure 11. CE# CONTROLLED WRITE TIMING WAVEFORM	40



Figure 12. AUTOMATIC PROGRAMMING ALGORITHM FLOWCHART	41
SECTOR PROTECT/CHIP UNPROTECT	42
Figure 13. SECTOR PROTECT/CHIP UNPROTECT WAVEFORM (RESET# Control)	42
Figure 14. IN-SYSTEM SECTOR PROTECT WITH RESET#=V _h v	43
Figure 15. CHIP UNPROTECT ALGORITHMS WITH RESET#=V _h v	44
Figure 16. TEMPORARY SECTOR UNPROTECT WAVEFORM	45
Table 5. TEMPORARY SECTOR UNPROTECT	45
Figure 17. TEMPORARY SECTOR UNPROTECT FLOWCHART	46
Figure 18. SILICON ID READ TIMING WAVEFORM	47
WRITE OPERATION STATUS	48
Figure 19. DATA# POLLING TIMING WAVEFORM (DURING AUTOMATIC ALGORITHM)	48
Figure 20. DATA# POLLING ALGORITHM	49
Figure 21. TOGGLE BIT TIMING WAVEFORM (DURING AUTOMATIC ALGORITHM)	50
Figure 22. TOGGLE BIT ALGORITHM	51
Figure 23. BYTE# TIMING WAVEFORM FOR READ OPERATIONS (BYTE# switching from byte mode to ... word mode)	52
RECOMMENDED OPERATING CONDITIONS	53
ERASE AND PROGRAMMING PERFORMANCE	54
LATCH-UP CHARACTERISTICS	54
ORDERING INFORMATION	55
PART NAME DESCRIPTION	56
PACKAGE INFORMATION	57
REVISION HISTORY	58



ADVANCED INFORMATION

KH29LV160D T/B

16M-BIT [2M x 8 / 1M x 16] 3V SUPPLY FLASH MEMORY

FEATURES

GENERAL FEATURES

- Byte/Word mode switchable
 - 2,097,152 x8 / 1,048,576 x16
- Sector Structure
 - 16K-Byte x 1, 8K-Byte x 2, 32K-Byte x 1, 64K-Byte x 31
 - Provides sector protect function to prevent program or erase operation in the protected sector
 - Provides chip unprotect function to allow code changing
 - Provides temporary sector unprotect function for code changing in previously protected sector
- Power Supply Operation
 - Vcc 2.7 to 3.6 volt for read, erase, and program operations
- Latch-up protected to 100mA from -1V to 1.5 x Vcc
- Low Vcc write inhibit : Vcc <= V_{Iko}
- Compatible with JEDEC standard
 - Pinout and software compatible to single power supply Flash

PERFORMANCE

- High Performance
 - Fast access time: 70ns
 - Word program time: 11us/word (typical)
 - Fast erase time: 0.7s/sector, 15s/chip (typical)
- Low Power Consumption
 - Low active read current: 7mA (typical) at 5MHz
 - Low standby current: 5uA (typical)
- Typical 100,000 erase/program cycle
- 10 years data retention

SOFTWARE FEATURES

- Erase Suspend/ Erase Resume
 - Suspends sector erase operation to read data from or program data to another sector which is not being erased
- Status Reply
 - Data# Polling & Toggle bits provide detection of program and erase operation completion
- Support Common Flash Interface (CFI)

HARDWARE FEATURES

- Ready/Busy# (RY/BY#) Output
 - Provides a hardware method of detecting program and erase operation completion
- Hardware Reset (RESET#) Input
 - Provides a hardware method to reset the internal state machine to read mode
- WP#/ACC
 - Provide accelerated program capability

PACKAGE

- 48-Pin TSOP
- **All Pb-free devices are RoHS Compliant**



GENERAL DESCRIPTION

KH29LV160DT/B is a 16Mbit flash memory that can be organized as 2Mbytes of 8 bits each or as 1Mwords of 16 bits each. These devices operate over a voltage range of 2.7V to 3.6V typically using a 3V power supply input. The memory array is divided into 32 equal 64 Kilo byte blocks. However, depending on the device being used as a Top-Boot or Bottom-Boot device. The outermost one sector at the top or at the bottom are respectively the boot blocks for this device.

The KH29LV160DT/B is offered in a 48-pin TSOP JEDEC standard package. These packages are offered in leaded, as well as lead-free versions that are compliant to the RoHS specifications. The software algorithm used for this device also adheres to the JEDEC standard for single power supply devices. These flash parts can be programmed in system or on commercially available EPROM/Flash programmers.

Separate OE# and CE# (Output Enable and Chip Enable) signals are provided to simplify system design. When used with high speed processors, the 70ns read access time of this flash memory permits operation with minimal time lost due to system timing delays.

The automatic write algorithm provided on Macronix flash memories perform an automatic erase prior to write. The user only needs to provide a write command to the command register. The on-chip state machine automatically controls the program and erase functions including all necessary internal timings. Since erase and write operations take much longer time than read operations, erase/write can be interrupted to perform read operations in other sectors of the device. For this, Erase Suspend operation along with Erase Resume operation are provided. Data# polling or Toggle bits are used to indicate the end of the erase/write operation.

These devices are manufactured at the Macronix fabrication facility using the time tested and proven MXIC's advance technology. This proprietary non-epi process provides a very high degree of latch-up protection for stresses up to 100 milliamperes on address and data pins from -1V to 1.5xVCC.

With low power consumption and enhanced hardware and software features, this flash memory retains data reliably for at least ten years. Erase and programming functions have been tested to meet a typical specification of 100,000 cycles of operation.



ADVANCED INFORMATION

KH29LV160D T/B

PIN CONFIGURATIONS

48TSOP (Standard Type) (12mm x 20mm)

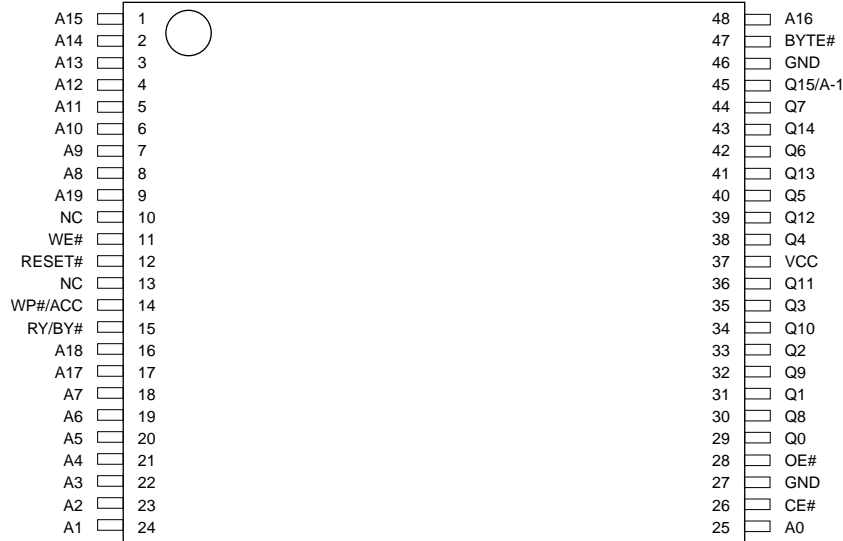

PIN DESCRIPTION

SYMBOL	PIN NAME
A0~A19	Address Input
Q0~Q14	Data Input/Output
Q15/A-1	Q15(Word mode)/LSB addr(Byte mode)
CE#	Chip Enable Input
WE#	Write Enable Input
BYTE#	Word/Byte Selection input
RESET#	Hardware Reset Pin/Sector Protect Unlock
OE#	Output Enable Input
RY/BY#	Ready/Busy Output
VCC	Power Supply Pin (2.7V~3.6V)
GND	Ground Pin
WP#/ACC	Hardware write Protect/Acceleration Pin
NC	Pin Not Connected Internally

Note: If customer does not need WP#/ACC feature please connect WP#/ACC pin to VCC or let it floating.

LOGIC SYMBOL

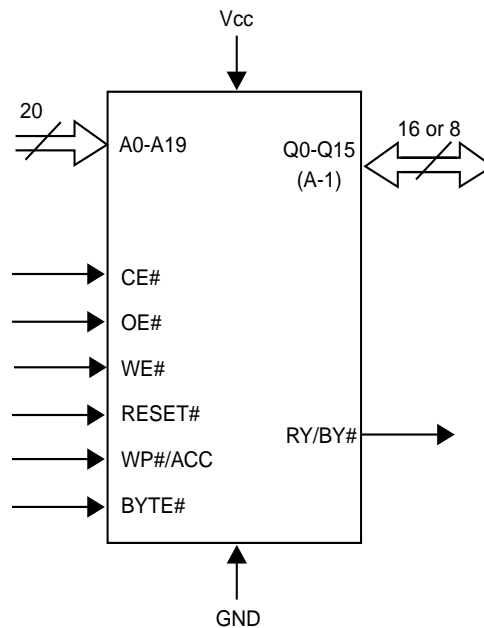



ADVANCED INFORMATION

KH29LV160D T/B

BLOCK DIAGRAM

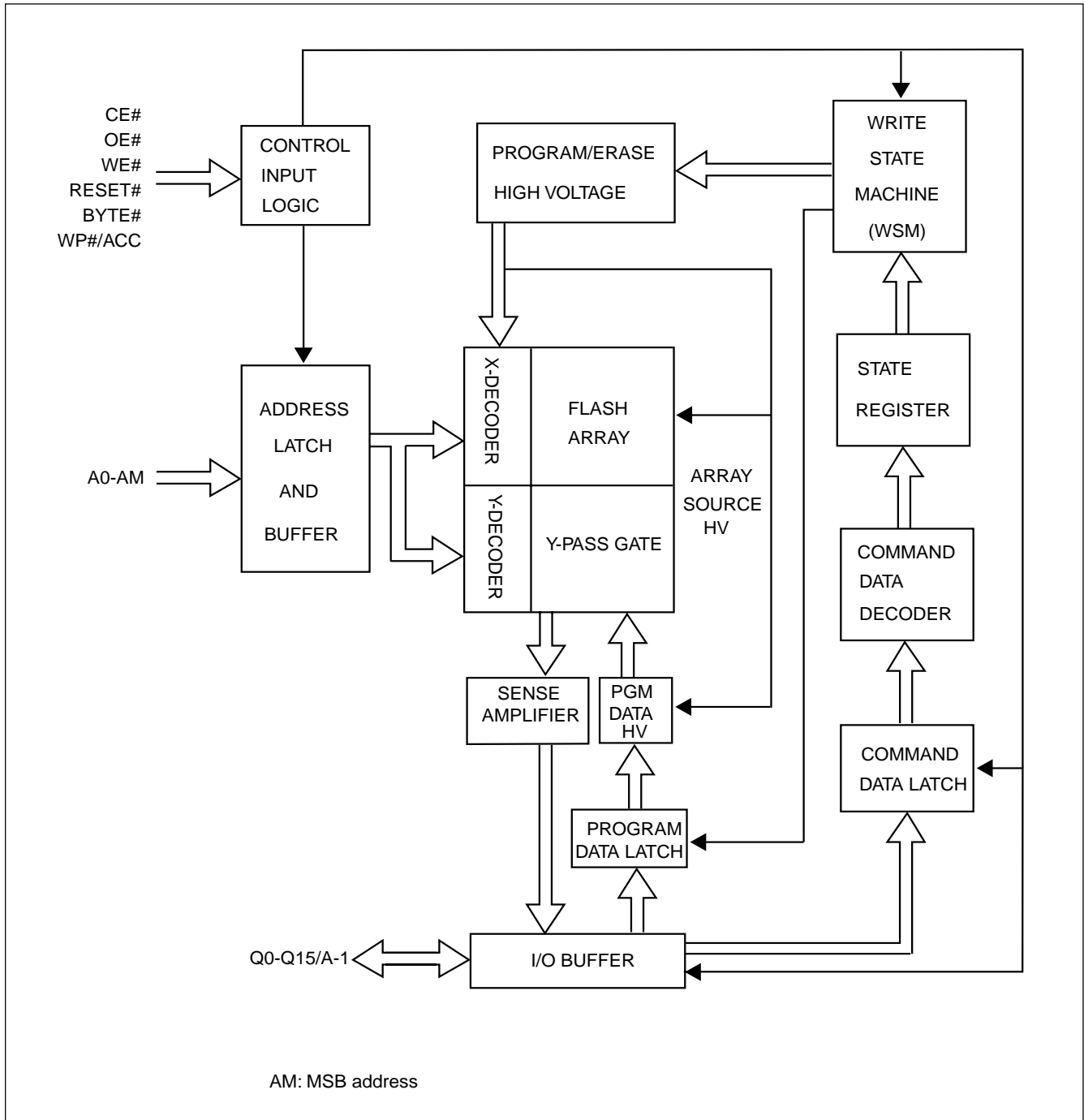



BLOCK DIAGRAM DESCRIPTION

The block diagram on Page 8 illustrates a simplified architecture of KH29LV160D T/B. Each block in the block diagram represents one or more circuit modules in the real chip used to access, erase, program, and read the memory array..

The "CONTROL INPUT LOGIC" block receives input pins CE#, OE#, WE#, RESET#, BYTE# and WP#/ACC. It creates internal timing control signals according to the input pins and outputs to the "ADDRESS LATCH AND BUFFER" to latch the external address pins A0-AM(A19). The internal addresses are output from this block to the main array and decoders composed of "X-DECODER", "Y-DECODER", "Y-PASS GATE", and "FLASH ARRAY". The X-DECODER decodes the word-lines of the flash array, while the Y-DECODER decodes the bit-lines of the flash array. The bit lines are electrically connected to the "SENSE AMPLIFIER" and "PGM DATA HV" selectively through the y-pass gates. Sense amplifiers are used to read out the contents of the flash memory, while the "PGM DATA HV" block is used to selectively deliver high power to bit-lines during programming. The "I/O BUFFER" controls the input and output on the Q0-Q15/A-1 pads. During read operation, the I/O buffer receives data from sense amplifiers and drives the output pads accordingly. In the last cycle of program command, the I/O buffer transmits the data on Q0-Q15/A-1 to "PROGRAM DATA LATCH", which controls the high power drivers in "PGM DATA HV" to selectively program the bits in a word or byte according to the user input pattern.

The "PROGRAM/ERASE HIGH VOLTAGE" block comprises the circuits to generate and deliver the necessary high voltage to the X-DECODER flash array, and "PGM DATA HV" block. The logic control module comprises of the "WRITE STATE MACHINE(WSM)", "STATE REGISTER", "COMMAND DATA DECODER", and "COMMAND DATA LATCH". When the user issues a command by toggling WE#, the command on Q0-A15/A-1 is latched in the command data latch and is decoded by the command data decoder. The state register receives the command and records the current state of the device. The WSM implements the internal algorithms for program or erase according to the current command state by controlling each block in the block diagram.



ADVANCED INFORMATION

KH29LV160D T/B

BLOCK STRUCTURE

The main flash memory array can be organized as 2M Bytes x 8 or as 1M Words x 16. The details of the address ranges and the corresponding sector addresses are shown in Table 1. Table 1.a shows the sector architecture for the Top Boot part, whereas Table 1.b shows the sector architecture for the Bottom Boot part. The specific security sector addresses are shown at the bottom off each of these tables.

Table 1-1. KH29LV160DT SECTOR ARCHITECTURE

Sector Size		Sector	Sector Address A19-A12	Address Range	
Byte Mode (Kbytes)	Word Mode (Kwords)			Byte Mode (x8)	Word Mode (x16)
64	32	SA0	0000xxx	000000h-00FFFFh	000000h-07FFFh
64	32	SA1	00001xxx	010000h-01FFFFh	008000h-0FFFFh
64	32	SA2	00010xxx	020000h-02FFFFh	010000h-17FFFh
64	32	SA3	00011xxx	030000h-03FFFFh	018000h-01FFFFh
64	32	SA4	00100xxx	040000h-04FFFFh	020000h-027FFFh
64	32	SA5	00101xxx	050000h-05FFFFh	028000h-02FFFFh
64	32	SA6	00110xxx	060000h-06FFFFh	030000h-037FFFh
64	32	SA7	00111xxx	070000h-07FFFFh	038000h-03FFFFh
64	32	SA8	01000xxx	080000h-08FFFFh	040000h-047FFFh
64	32	SA9	01001xxx	090000h-09FFFFh	048000h-04FFFFh
64	32	SA10	01010xxx	0A0000h-0AFFFFh	050000h-057FFFh
64	32	SA11	01011xxx	0B0000h-0BFFFFh	058000h-05FFFFh
64	32	SA12	01100xxx	0C0000h-0CFFFFh	060000h-067FFFh
64	32	SA13	01101xxx	0D0000h-0DFFFFh	068000h-06FFFFh
64	32	SA14	01110xxx	0E0000h-0EFFFFh	070000h-077FFFh
64	32	SA15	01111xxx	0F0000h-0FFFFFh	078000h-07FFFFh
64	32	SA16	10000xxx	100000h-10FFFFh	080000h-087FFFh
64	32	SA17	10001xxx	110000h-11FFFFh	088000h-08FFFFh
64	32	SA18	10010xxx	120000h-12FFFFh	090000h-097FFFh
64	32	SA19	10011xxx	130000h-13FFFFh	098000h-09FFFFh
64	32	SA20	10100xxx	140000h-14FFFFh	0A0000h-0A7FFFh
64	32	SA21	10101xxx	150000h-15FFFFh	0A8000h-0AFFFFh
64	32	SA22	10110xxx	160000h-16FFFFh	0B0000h-0B7FFFh
64	32	SA23	10111xxx	170000h-17FFFFh	0B8000h-0BFFFFh
64	32	SA24	11000xxx	180000h-18FFFFh	0C0000h-0C7FFFh
64	32	SA25	11001xxx	190000h-19FFFFh	0C8000h-0CFFFFh
64	32	SA26	11010xxx	1A0000h-1AFFFFh	0D0000h-0D7FFFh
64	32	SA27	11011xxx	1B0000h-1BFFFFh	0D8000h-0DFFFFh
64	32	SA28	11100xxx	1C0000h-1CFFFFh	0E0000h-0E7FFFh
64	32	SA29	11101xxx	1D0000h-1DFFFFh	0E8000h-0EFFFFh
64	32	SA30	11110xxx	1E0000h-1EFFFFh	0F0000h-0F7FFFh
32	16	SA31	111110xx	1F0000h-1F7FFFh	0F8000h-0FBFFFh
8	4	SA32	11111100	1F8000h-1F9FFFh	0FC000h-0FCFFFh
8	4	SA33	11111101	1FA000h-1FBFFFh	0FD000h-0FDFFFh
16	8	SA34	1111111x	1FC000h-1FFFFFh	0FE000h-0FFFFFh



ADVANCED INFORMATION

KH29LV160D T/B

Table 1-2. KH29LV160DB SECTOR ARCHITECTURE

Sector Size		Sector	Sector Address A19-A12	Address Range	
Byte Mode (Kbytes)	Word Mode (Kwords)			Byte Mode (x8)	Word Mode (x16)
16	8	SA0	000000x	000000h-003FFFh	000000h-001FFFh
8	4	SA1	00000010	004000h-005FFFh	002000h-002FFFh
8	4	SA2	00000011	006000h-007FFFh	003000h-003FFFh
32	16	SA3	000001xx	008000h-00FFFFh	004000h-007FFFh
64	32	SA4	00001xxx	010000h-01FFFFh	008000h-00FFFFh
64	32	SA5	00010xxx	020000h-02FFFFh	010000h-017FFFh
64	32	SA6	00011xxx	030000h-03FFFFh	018000h-01FFFFh
64	32	SA7	00100xxx	040000h-04FFFFh	020000h-027FFFh
64	32	SA8	00101xxx	050000h-05FFFFh	028000h-02FFFFh
64	32	SA9	00110xxx	060000h-06FFFFh	030000h-037FFFh
64	32	SA10	00111xxx	070000h-07FFFFh	038000h-03FFFFh
64	32	SA11	01000xxx	080000h-08FFFFh	040000h-047FFFh
64	32	SA12	01001xxx	090000h-09FFFFh	048000h-04FFFFh
64	32	SA13	01010xxx	0A0000h-0AFFFFh	050000h-057FFFh
64	32	SA14	01011xxx	0B0000h-0BFFFFh	058000h-05FFFFh
64	32	SA15	01100xxx	0C0000h-0CFFFFh	060000h-067FFFh
64	32	SA16	01101xxx	0D0000h-0DFFFFh	068000h-06FFFFh
64	32	SA17	01110xxx	0E0000h-0EFFFFh	070000h-077FFFh
64	32	SA18	01111xxx	0F0000h-0FFFFFh	078000h-07FFFFh
64	32	SA19	10000xxx	100000h-10FFFFh	080000h-087FFFh
64	32	SA20	10001xxx	110000h-11FFFFh	088000h-08FFFFh
64	32	SA21	10010xxx	120000h-12FFFFh	090000h-097FFFh
64	32	SA22	10011xxx	130000h-13FFFFh	098000h-09FFFFh
64	32	SA23	10100xxx	140000h-14FFFFh	0A0000h-0A7FFFh
64	32	SA24	10101xxx	150000h-15FFFFh	0A8000h-0AFFFFh
64	32	SA25	10110xxx	160000h-16FFFFh	0B0000h-0B7FFFh
64	32	SA26	10111xxx	170000h-17FFFFh	0B8000h-0BFFFFh
64	32	SA27	11000xxx	180000h-18FFFFh	0C0000h-0C7FFFh
64	32	SA28	11001xxx	190000h-19FFFFh	0C8000h-0CFFFFh
64	32	SA29	11010xxx	1A0000h-1AFFFFh	0D0000h-0D7FFFh
64	32	SA30	11011xxx	1B0000h-1BFFFFh	0D8000h-0DFFFFh
64	32	SA31	11100xxx	1C0000h-1CFFFFh	0E0000h-0E7FFFh
64	32	SA32	11101xxx	1D0000h-1DFFFFh	0E8000h-0EFFFFh
64	32	SA33	11110xxx	1E0000h-1EFFFFh	0F0000h-0F7FFFh
64	32	SA34	11111xxx	1F0000h-1FFFFFh	0F8000h-0FFFFFh



BUS OPERATION

Table 2-1. BUS OPERATION

Mode Select	RE-SET#	CE#	WE#	OE#	Address	Data (I/O) Q0~Q7	Byte#		WP#/ACC
							Vil	Vih	
							Data (I/O) Q8~Q15		
Device Reset	L	X	X	X	X	HighZ	HighZ	HighZ	L/H
Standby Mode	Vcc± 0.3V	Vcc± 0.3V	X	X	X	HighZ	HighZ	HighZ	H
Output Disable	H	L	H	H	X	HighZ	HighZ	HighZ	L/H
Read Mode	H	L	H	L	AIN	DOUT	Q8-Q14=	DOUT	L/H
Write(Note1)	H	L	L	H	AIN	DIN	HighZ	DIN	Note3
Accelerate Program	H	L	L	H	AIN	DIN	Q15= A-1	DIN	Vhv
Temporary Sector Unprotect	Vhv	X	X	X	AIN	DIN	HighZ	DIN	Note3
Sector Protect (Note2)	Vhv	L	L	H	Sector Address, A6=L, A1=H, A0=L	DIN, DOUT	X	X	L/H
Chip Unprotect (Note2)	Vhv	L	L	H	Sector Address, A6=H, A1=H, A0=L	DIN, DOUT	X	X	Note3

Notes:

1. All sectors will be unprotected if WP#/ACC=Vhv.
2. The one outmost boot sector is protected if WP#/ACC=Vil.
3. When WP#/ACC = Vih, the protection conditions of the one outmost boot sector depend on previous protection conditions. "Sector/Sector Block Protection and Unprotection" describes the protect and unprotect method.
4. Q0~Q15 are input (DIN) or output (DOUT) pins according to the requests of command sequence, sector protection, or data polling algorithm.
5. In Word Mode (Byte#=Vih), the addresses are AM to A0.
In Byte Mode (Byte#=Vil), the addresses are AM to A-1 (Q15).
6. AM: MSB of address.



ADVANCED INFORMATION

KH29LV160D T/B

Table 2-2. BUS OPERATION

Item	Control Input			AM	A11		A8		A5		A0	Q0~Q7	Q8~Q15
	CE#	WE#	OE#	to A12	to A10	A9	to A7	A6	to A2	A1	A0		
Sector Lock Status Verification	L	H	L	SA	x	V _{hv}	x	L	x	H	L	01h or 00h (Note1)	x
Read Silicon ID Manufacturer Code	L	H	L	x	x	V _{hv}	x	L	x	L	L	C2h	x
Read Silicon ID KH29LV160DT	L	H	L	x	x	V _{hv}	x	L	x	L	H	C4h	22h(Word) x (Byte)
Read Silicon ID KH29LV160DB	L	H	L	x	x	V _{hv}	x	L	x	L	H	49h	22h(Word) x (Byte)

Notes:

1. Sector unprotected code:00h. Sector protected code:01h.
2. AM: MSB of address.



FUNCTIONAL OPERATION DESCRIPTION

WRITE COMMANDS/COMMAND SEQUENCES

To write a command to the device, system must drive WE# and CE# to Vil, and OE# to Vih. In a command cycle, all address are latched at the later falling edge of CE# and WE#, and all data are latched at the earlier rising edge of CE# and WE#.

Figure 1 illustrates the AC timing waveform of a write command, and Table 3 defines all the valid command sets of the device. System is not allowed to write invalid commands not defined in this datasheet. Writing an invalid command will bring the device to an undefined state.

REQUIREMENTS FOR READING ARRAY DATA

Read array action is to read the data stored in the array. While the memory device is in powered up or has been reset, it will automatically enter the status of read array. If the microprocessor wants to read the data stored in array, it has to drive CE# (device enable control pin) and OE# (Output control pin) as Vil, and input the address of the data to be read into address pin at the same time. After a period of read cycle (Tce or Taa), the data being read out will be displayed on output pin for microprocessor to access. If CE# or OE# is Vih, the output will be in tri-state, and there will be no data displayed on output pin at all.

After the memory device completes embedded operation (automatic Erase or Program), it will automatically return to the status of read array, and the device can read the data in any address in the array. In the process of erasing, if the device receives the Erase suspend command, erase operation will be stopped temporarily after a period of time no more than Tready1 and the device will return to the status of read array. At this time, the device can read the data stored in any address except the sector being erased in the array. In the status of erase suspend, if user wants to read the data in the sectors being erased, the device will output status data onto the output. Similarly, if program command is issued after erase suspend, after program operation is completed, system can still read array data in any address except the sectors to be erased

The device needs to issue reset command to enable read array operation again in order to arbitrarily read the data in the array in the following two situations:

1. In program or erase operation, the programming or erasing failure causes Q5 to go high.
2. The device is in auto select mode or CFI mode.

In the two situations above, if reset command is not issued, the device is not in read array mode and system must issue reset command before reading array data.



RESET# OPERATION

Driving RESET# pin low for a period more than T_{rp} will reset the device back to read mode. If the device is in program or erase operation, the reset operation will take at most a period of T_{ready1} for the device to return to read array mode. Before the device returns to read array mode, the RY/BY# pin remains low (busy status).

When RESET# pin is held at $GND \pm 0.3V$, the device consumes standby current (I_{sb}). However, device draws larger current if RESET# pin is held at V_{il} but not within $GND \pm 0.3V$.

It is recommended that the system to tie its reset signal to RESET# pin of flash memory, so that the flash memory will be reset during system reset and allows system to read boot code from flash memory.

SECTOR PROTECT OPERATION

When a sector is protected, program or erase operation will be disabled on that protected sector. KH29LV160D T/B provides two methods for sector protection.

Once the sector is protected, the sector remains protected until next chip unprotect, or is temporarily unprotected by asserting RESET# pin at V_{hv} . Refer to temporary sector unprotect operation for further details.

The first method is by applying V_{hv} on RESET# pin. Refer to Figure 12 for timing diagram and Figure 13 for the algorithm for this method.

The other method is asserting V_{hv} on A9 and OE# pins, with A6 and CE# at V_{il} . The protection operation begins at the falling edge of WE# and terminates at the rising edge. Contact Macronix for details.

CHIP UNPROTECT OPERATION

KH29LV160D T/B provides two methods for chip unprotect. The chip unprotect operation unprotects all sectors within the device. It is recommended to protect all sectors before activating chip unprotect mode. All sectors are unprotected when shipped from the factory.

The first method is by applying V_{hv} on RESET# pin. Refer to Figure 12 for timing diagram and Figure 14 for algorithm of the operation.

The other method is asserting V_{hv} on A9 and OE# pins, with A6 at V_{ih} and CE# at V_{il} . The unprotect operation begins at the falling edge of WE# and terminates at the rising edge. Contact Macronix for details.

HARDWAREWRITE PROTECT

By driving the WP#/ACC pin LOW, the outermost one boot sector is protected from all erase/program operations. If WP#/ACC is held HIGH (V_{ih} to VCC), the one outermost sector revert to its previously protected/unprotected status.

ACCELERATED PROGRAMMING OPERATION

By applying high voltage (V_{hv}) to the WP#/ACC pin, the device will enter the Accelerated Programming mode. This mode permits the system to skip the normal command unlock sequences and program byte/word locations directly. Typically, this mode provides a 30% reduction in overall programming times. During accelerated programming, the



current drawn from the WP#/ACC pin is no more than ICP1.

TEMPORARY SECTOR UNPROTECT OPERATION

System can apply RESET# pin at V_{hv} to place the device in temporary unprotect mode. In this mode, previously protected sectors can be programmed or erased just as it is unprotected. The device returns to normal operation once V_{hv} is removed from RESET# pin and previously protected sectors are again protected.

AUTOMATIC SELECT OPERATION

When the device is in Read array mode, erase-suspended read array mode or CFI mode, user can issue read silicon ID command to enter read silicon ID mode. After entering read silicon ID mode, user can query several silicon IDs continuously and does not need to issue read silicon ID mode again. When A0 is Low, device will output Macronix Manufacture ID C2. When A0 is high, device will output Device ID. In read silicon ID mode, issuing reset command will reset device back to read array mode or erase-suspended read array mode.

Another way to enter read silicon ID is to apply high voltage on A9 pin with CE#, OE#, A6 and A1 at V_{il}. While the high voltage of A9 pin is discharged, device will automatically leave read silicon ID mode and go back to read array mode or erase-suspended read array mode. When A0 is Low, device will output Macronix Manufacture ID C2. When A0 is high, device will output Device ID.

VERIFY SECTOR PROTECT STATUS OPERATION

KH29LV160D T/B provides hardware sector protection against Program and Erase operation for protected sectors. The sector protect status can be read through Sector Protect Verify command. This method requires V_{hv} on A9 pin, V_{ih} on WE# and A1 pins, V_{il} on CE#, OE#, A6 and A0 pins, and sector address on A12 to A_m pins. If the read out data is 01h, the designated sector is protected. Oppositely, if the read out data is 00h, the designated sector is not protected.

DATA PROTECTION

To avoid accidental erasure or programming of the device, the device is automatically reset to read array mode during power up. Besides, only after successful completion of the specified command sets will the device begin its erase or program operation.

Other features to protect the data from accidental alternation are described as followed.

LOW VCC WRITE INHIBIT

The device refuses to accept any write command when V_{cc} is less than V_{lko}. This prevents data from spuriously altered. The device automatically resets itself when V_{cc} is lower than V_{lko} and write cycles are ignored until V_{cc} is greater than V_{lko}. System must provide proper signals on control pins after V_{cc} is larger than V_{lko} to avoid unintentional program or erase operation

WRITE PULSE "GLITCH" PROTECTION



CE#, WE#, OE# pulses shorter than 5ns are treated as glitches and will not be regarded as an effective write cycle.

LOGICAL INHIBIT

A valid write cycle requires both CE# and WE# at V_{il} with OE# at V_{ih} . Write cycle is ignored when either CE# at V_{ih} , WE# at V_{ih} , or OE# at V_{il} .

POWER-UP SEQUENCE

Upon power up, KH29LV160DT/B is placed in read array mode. Furthermore, program or erase operation will begin only after successful completion of specified command sequences.

POWER-UP WRITE INHIBIT

When WE#, CE# is held at V_{il} and OE# is held at V_{ih} during power up, the device ignores the first command on the rising edge of WE#.

POWER SUPPLY DECOUPLING

A 0.1 μ F capacitor should be connected between the Vcc and GND to reduce the noise effect.



ADVANCED INFORMATION

KH29LV160D T/B

COMMAND OPERATIONS

TABLE 3. KH29LV160DT/B COMMAND DEFINITIONS

Command	Hex	Read Mode	Reset Mode	Automatic Select						Program	
				Manufacture ID		Device ID		Sector Protect Verify			
				Word	Byte	Word	Byte	Word	Byte	Word	Byte
1st Bus	Address	Address	XXX	555	AAA	555	AAA	555	AAA	555	AAA
Cycle	Data	Data	F0	AA	AA	AA	AA	AA	AA	AA	AA
2nd Bus	Address			2AA	555	2AA	555	2AA	555	2AA	555
Cycle	Data			55	55	55	55	55	55	55	55
3rd Bus	Address			555	AAA	555	AAA	555	AAA	555	AAA
Cycle	Data			90	90	90	90	90	90	A0	A0
4th Bus	Address			X00	X00	X01	X02	(Sector) X02	(Sector)X04	Address	Address
Cycle	Data			C2	C2	ID	ID	00/01	00/01	Data	Data
5th Bus	Address										
Cycle	Data										
6th Bus	Address										
Cycle	Data										

Command	Hex	Chip Erase		Sector Erase		CFI Read		Erase Suspend	Erase Resume
		Word	Byte	Word	Byte	Word	Byte	Byte/Word	Byte/Word
1st Bus	Address	555	AAA	555	AAA	55	AA	XXX	XXX
Cycle	Data	AA	AA	AA	AA	98	98	B0	30
2nd Bus	Address	2AA	555	2AA	555				
Cycle	Data	55	55	55	55				
3rd Bus	Address	555	AAA	555	AAA				
Cycle	Data	80	80	80	80				
4th Bus	Address	555	AAA	555	AAA				
Cycle	Data	AA	AA	AA	AA				
5th Bus	Address	2AA	555	2AA	555				
Cycle	Data	55	55	55	55				
6th Bus	Address	555	AAA	Sector	Sector				
Cycle	Data	10	10	30	30				

Notes:

1. Device ID : KH29LV160DT: 22C4; KH29LV160DB: 2249.
2. For sector protect verify result, XX00h/00h means sector is not protected, XX01h/01h means sector has been protected.
3. Sector Protect command is valid during V_{hv} at RESET# pin, V_{ih} at A1 pin and V_{il} at A0, A6 pins. The last Bus cyc is for protect verify.
4. It is not allowed to adopt any other code which is not in the above command definition table.



COMMAND OPERATIONS (cont'd)

AUTOMATIC PROGRAMMING OF THE MEMORY ARRAY

The KH29LV160D T/B provides the user the ability to program the memory array in Byte mode or Word mode. As long as the users enters the correct cycle defined in the Table 3 (including 2 unlock cycles and the A0h program command), any byte or word data provided on the data lines by the system will automatically be programmed into the array at the specified location.

After the program command sequence has been executed, the internal write state machine (WSM) automatically executes the algorithms and timings necessary for programming and verification, which includes generating suitable program pulses, checking cell threshold voltage margins, and repeating the program pulse if any cells do not pass verification or have low margins. The internal controller protects cells that do pass verification and margin tests from being over-programmed by inhibiting further program pulses to these passing cells as weaker cells continue to be programmed.

With the internal WSM automatically controlling the programming process, the user only needs to enter the program command and data once.

Programming will only change the bit status from "1" to "0". It is not possible to change the bit status from "0" to "1" by programming. This can only be done by an erase operation. Furthermore, the internal write verification only checks and detects errors in cases where a "1" is not successfully programmed to "0".

Any commands written to the device during programming will be ignored except hardware reset, which will terminate the program operation after a period of time no more than Tready1. When the embedded program algorithm is complete or the program operation is terminated by a hardware reset, the device will return to Read mode.

After the embedded program operation has begun, the user can check for completion by reading the following bits in the status register:

Status	Q7 ^{*1}	Q6 ^{*1}	Q5	RY/BY# ^{*2}
In progress *3	Q7#	Toggling	0	0
Finished	Q7	Stop toggling	0	1
Exceed time limit	Q7#	Toggling	1	0

*1: When an attempt is made to program a protected sector, the program operation will abort thus preventing any data changes in the protected sector. Q7 will output complement data and Q6 will toggle briefly (1 us or less) before aborting and returning the device to Read mode.

*2: RY/BY# is an open drain output pin and should be connected to VCC through a high value pull-up resistor.

*3: The status "in progress" means both program and erase-suspended program mode.

ERASING THE MEMORY ARRAY

There are two types of erase operations performed on the memory array -- Sector Erase and Chip Erase. In the Sector Erase operation, one or more selected sectors may be erased simultaneously. In the Chip Erase operation, the complete memory array is erased except for any protected sectors.



COMMAND OPERATIONS (cont'd)

SECTOR ERASE

The sector erase operation is used to clear data within a sector by returning all of its memory locations to the "1" state. It requires six command cycles to initiate the erase operation. The first two cycles are "unlock cycles", the third is a configuration cycle, the fourth and fifth are also "unlock cycles", and the sixth cycle is the Sector Erase command. After the sector erase command sequence has been issued, an internal 50us time-out counter is started. Until this counter reaches zero, additional sector addresses and Sector Erase commands may be issued thus allowing multiple sectors to be selected and erased simultaneously. After the 50us time-out counter has expired, no new commands will be accepted and the embedded sector erase operation will begin. Note that the 50us timer-out counter is restarted after every erase command sequence. If the user enters any command other than Sector Erase or Erase Suspend during the time-out period, the erase operation will abort and the device will return to Read mode.

After the embedded sector erase operation begins, all commands except Erase Suspend will be ignored. The only way to interrupt the operation is with an Erase Suspend command or with a hardware reset. The hardware reset will completely abort the operation and return the device to Read mode.

The system can determine the status of the embedded sector erase operation by the following methods:

Status	Q7	Q6	Q5	Q3 (note 1)	Q2	RY/BY#(note 2)
Time-out period	0	Toggling	0	0	Toggling	0
In progress	0	Toggling	0	1	Toggling	0
Finished	1	Stop toggling	0	1	1	1
Exceeded time limit	0	Toggling	1	1	Toggling	0

Note :

1. The Q3 status bit is the time-out indicator. When Q3=0, the time-out counter has not yet reached zero and a new Sector Erase command may be issued to specify the address of another sector to be erased. When Q3=1, the time-out counter has expired and the Sector Erase operation has already begun. Erase Suspend is the only valid command that may be issued once the embedded erase operation is underway.
2. RY/BY# is an open drain output pin and should be connected to VCC through a high value pull-up resistor.
3. When an attempt is made to erase only protected sector(s), the program operation will abort thus preventing any data changes in the protected sector(s). Q7 will output its complement data and Q6 will toggle briefly (100us or less) before aborting and returning the device to Read mode. If unprotected sectors are also specified, however, they will be erased normally and the protected sector(s) will remain unchanged.
4. Q2 is a localized indicator showing a specified sector is undergoing erase operation or not. Q2 toggles when user reads at addresses where the sectors are actively being erased (in erase mode) or to be erased (in erase suspend mode). When a sector has been completely erased, Q2 stops toggling at the sector even when the device is still in erase operation for remaining selected sectors. At that circumstance, Q2 will still toggle when device is read at any other sector that remains to be erased.



COMMAND OPERATIONS (cont'd)

CHIP ERASE

The Chip Erase operation is used to erase all the data within the memory array. All memory cells containing a "0" will be returned to the erased state of "1". This operation requires 6 write cycles to initiate the action. The first two cycles are "unlock" cycles, the third is a configuration cycle, the fourth and fifth are also "unlock" cycles, and the sixth cycle initiates the chip erase operation.

During the chip erase operation, no other software commands will be accepted, but if a hardware reset is received or the working voltage is too low, that chip erase will be terminated. After Chip Erase, the chip will automatically return to Read mode.

The system can determine the status of the embedded chip erase operation by the following methods:

Status	Q7	Q6	Q5	Q2	RY/BY# ^{*1}
In progress	0	Toggling	0	Toggling	0
Finished	1	Stop toggling	0	1	1
Exceed time limit	0	Toggling	1	Toggling	0

*1: RY/BY# is an open drain output pin and should be connected to VCC through a high value pull-up resistor.

SECTOR ERASE SUSPEND

After beginning a sector erase operation, Erase Suspend is the only valid command that may be issued. If system issues an Erase Suspend command during the 50us time-out period following a Sector Erase command, the time-out period will terminate immediately and the device will enter Erase-Suspended Read mode. If the system issues an Erase Suspend command after the sector erase operation has already begun, the device will not enter Erase-Suspended Read mode until Tready1 time has elapsed. The system can determine if the device has entered the Erase-Suspended Read mode through Q6, Q7, and RY/BY#.

After the device has entered Erase-Suspended Read mode, the system can read or program any sector(s) except those being erased by the suspended erase operation. Reading any sector being erased or programmed will return the contents of the status register. Whenever a suspend command is issued, user must issue a resume command and check Q6 toggle bit status, before issue another erase command. The system can use the status register bits shown in the following table to determine the current state of the device:

Status	Q7	Q6	Q5	Q3	Q2	RY/BY#
Erase suspend read in erase suspended sector	1	No toggle	0	N/A	Toggle	1
Erase suspend read in non-erase suspended sector	Data	Data	Data	Data	Data	1
Erase suspend program in non-erase suspended sector	Q7#	Toggle	0	N/A	N/A	0

When the device has suspended erasing, user can execute the command sets except sector erase and chip erase, such as read silicon ID, sector protect verify, program, CFI query and erase resume.



COMMAND OPERATIONS (cont'd)

SECTOR ERASE RESUME

The sector Erase Resume command is valid only when the device is in Erase-Suspended Read mode. After erase resumes, the user can issue another Ease Suspend command, but there should be a 4ms interval between Ease Resume and the next Erase Suspend command. If the user enters an infinite suspend-resume loop, or suspend-resume exceeds 1024 times, erase times will increase dramatically.

AUTOMATIC SELECT OPERATIONS

When the device is in Read mode, Erase-Suspended Read mode, or CFI mode, the user can issue the Automatic Select command shown in Table 3 (two unlock cycles followed by the Automatic Select command 90h) to enter Automatic Select mode. After entering Automatic Select mode, the user can query the Manufacturer ID, Device ID, Security Sector locked status, or Sector-Group protected status multiple times without issuing a new Automatic Select command.

While In Automatic Select mode, issuing a Reset command (F0h) will return the device to Read mode (or Ease-Suspended Read mode if Erase-Suspend was active).

Another way to enter Automatic Select mode is to use one of the bus operations shown in Table 2-2. BUS OPERATION. After the high voltage (V_{hv}) is removed from the A9 pin, the device will automatically return to Read mode or Erase-Suspended Read mode.

AUTOMATIC SELECT COMMAND SEQUENCE

Automatic Select mode is used to access the manufacturer ID, device ID and to verify whether or not a sector is protected. The automatic select mode has four command cycles. The first two are unlock cycles, and followed by a specific command. The fourth cycle is a normal read cycle, and user can read at any address any number of times without entering another command sequence. The reset command is necessary to exit the Automatic Select mode and back to read array. The following table shows the identification code with corresponding address.

		Address (Hex)	Data (Hex)	Representation
Manufacturer ID	Word	X00	00C2	
	Byte	X00	C2	
Device ID	Word	X01	22C4/22C9	Top/Bottom Boot Sector
	Byte	X02	C4/C9	Top/Bottom Boot Sector
Sector Protect Verify	Word	(Sector address) X 02	0000/0001	Unprotected/protected
	Byte	(Sector address) X 04	00/01	Unprotected/protected

After entering automatic select mode, no other commands are allowed except the reset command.



COMMAND OPERATIONS (cont'd)

READ MANUFACTURER ID OR DEVICE ID

The Manufacturer ID (identification) is a unique hexadecimal number assigned to each manufacturer by the JEDEC committee. Each company has its own manufacturer ID, which is different from the ID of all other companies. The number assigned to Macronix is C2h.

The Device ID is a unique hexadecimal number assigned by the manufacturer for each one of the flash devices made by that manufacturer.

The above two ID types are stored in a 16-bit register on the flash device -- eight bits for each ID. This register is normally read by the user or by the programming machine to identify the manufacturer and the specific device.

After entering Automatic Select mode, performing a read operation with A1 & A0 held LOW will cause the device to output the Manufacturer ID on the Data I/O (Q7 to Q0) pins. Performing a read operation with A1 LOW and A0 HIGH will cause the device to output the Device ID.

VERIFY SECTOR GROUP PROTECTION

After entering Automatic Select mode, performing a read operation with A1 held HIGH and A0 held LOW and the address of the sector to be checked applied to A19 to A12, data bit Q0 will indicate the protected status of the addressed sector. If Q0 is HIGH, the sector is protected. Conversely, if Q0 is LOW, the sector is unprotected.

RESET

In the following situations, executing reset command will reset device back to read array mode:

- Among erase command sequence (before the full command set is completed)
- Sector erase time-out period
- Erase fail (while Q5 is high)
- Among program command sequence (before the full command set is completed, erase-suspended program included)
- Program fail (while Q5 is high, and erase-suspended program fail is included)
- Read silicon ID mode
- Sector protect verify
- CFI mode

While device is at the status of program fail or erase fail (Q5 is high), user must issue reset command to reset device back to read array mode. While the device is in read silicon ID mode, sector protect verify or CFI mode, user must issue reset command to reset device back to read array mode.

When the device is in the progress of programming (not program fail) or erasing (not erase fail), device will ignore reset command.



COMMON FLASH MEMORY INTERFACE (CFI) MODE

QUERY COMMAND AND COMMON FLASH INTERFACE (CFI) MODE

KH29LV160D T/B features CFI mode. Host system can retrieve the operating characteristics, structure and vendor-specified information such as identifying information, memory size, byte/word configuration, operating voltages and timing information of this device by CFI mode. If the system writes the CFI Query command "98h", to address "55h"/"AAh" (depending on Word/Byte mode), the device will enter the CFI Query Mode, any time the device is ready to read array data. The system can read CFI information at the addresses given in Table 4.

Once user enters CFI query mode, user can not issue any other commands except reset command. The reset command is required to exit CFI mode and go back to the mode before entering CFI. The system can write the CFI Query command only when the device is in read mode, erase suspend, standby mode or automatic select mode.

Table 4-1. CFI mode: Identification Data Values

(All values in these tables are in hexadecimal)

Description	Address(h)	Address(h)	Data(h)
	(Word Mode)	(Byte Mode)	
Query-unique ASCII string "QRY"	10	20	0051
	11	22	0052
	12	24	0059
Primary vendor command set and control interface ID code	13	26	0002
	14	28	0000
Address for primary algorithm extended query table	15	2A	0040
	16	2C	0000
Alternate vendor command set and control interface ID code	17	2E	0000
	18	30	0000
Address for alternate algorithm extended query table	19	32	0000
	1A	34	0000

Table 4-2. CFI Mode: System Interface Data Values

Description	Address(h)	Address(h)	Data(h)
	(Word Mode)	(Byte Mode)	
Vcc supply minimum program/erase voltage	1B	36	0027
Vcc supply maximum program/erase voltage	1C	38	0036
VPP supply minimum program/erase voltage	1D	3A	0000
VPP supply maximum program/erase voltage	1E	3C	0000
Typical timeout per single word/byte write, 2 ⁿ us	1F	3E	0004
Typical timeout for maximum-size buffer write, 2 ⁿ us	20	40	0000
Typical timeout per individual block erase, 2 ⁿ ms	21	42	000A
Typical timeout for full chip erase, 2 ⁿ ms	22	44	0000
Maximum timeout for word/byte write, 2 ⁿ times typical	23	46	0005
Maximum timeout for buffer write, 2 ⁿ times typical	24	48	0000
Maximum timeout per individual block erase, 2 ⁿ times typical	25	4A	0004
Maximum timeout for chip erase, 2 ⁿ times typical	26	4C	0000



ADVANCED INFORMATION

KH29LV160D T/B

Table 4-3. CFI Mode: Device Geometry Data Values

Description	Address (h)	Address (h)	Data (h)
	(Word Mode)	(Byte Mode)	
Device size = 2 ⁿ in number of bytes (KH29LV160D)	27	4E	0015
Flash device interface description (02=asynchronous x8/x16)	28	50	0002
	29	52	0000
Maximum number of bytes in buffer write = 2 ⁿ (not support)	2A	54	0000
	2B	56	0000
Number of erase regions within device	2C	58	0004
Index for Erase Bank Area 1	2D	5A	0000
[2E,2D] = # of same-size sectors in region 1-1	2E	5C	0000
[30, 2F] = sector size in multiples of 256-bytes	2F	5E	0040
	30	60	0000
Index for Erase Bank Area 2	31	62	0001
	32	64	0000
	33	66	0020
	34	68	0000
Index for Erase Bank Area 3	35	6A	0000
	36	6C	0000
	37	6E	0080
	38	70	0000
Index for Erase Bank Area 4 (for KH29LV160D)	39	72	001E
	3A	74	0000
	3B	76	0000
	3C	78	0001



ADVANCED INFORMATION

KH29LV160D T/B

Table 4-4. CFI Mode: Primary Vendor-Specific Extended Query Data Values

Description	Address (h)	Address (h)	Data (h)
	(Word Mode)	(Byte Mode)	
Query - Primary extended table, unique ASCII string, PRI	40	80	0050
	41	82	0052
	42	84	0049
Major version number, ASCII	43	86	0031
Minor version number, ASCII	44	88	0030
Unlock recognizes address (0= recognize, 1= don't recognize)	45	8A	0000
Erase suspend (2= to both read and program)	46	8C	0002
Sector protect (N= # of sectors/group)	47	8E	0001
Temporary sector unprotect (1=supported)	48	90	0001
Sector protect/Chip unprotect scheme	49	92	0004
Simultaneous R/W operation (0=not supported)	4A	94	0000
Burst mode (0=not supported)	4B	96	0000
Page mode (0=not supported)	4C	98	0000
Minimum acceleration supply (0= not supported), [D7:D4] for volt, [D3:D0] for 100mV	4D	9A	00A5
Maximum acceleration supply (0= not supported), [D7:D4] for volt, [D3:D0] for 100mV	4E	9C	00B5
Top/Bottom boot block indicator	4F	9E	0002/
02h=bottom boot device 03h=top boot device			0003



ELECTRICAL CHARACTERISTICS

ABSOLUTE MAXIMUM STRESS RATINGS

Surrounding Temperature with Bias	-65°C to +125°C
Storage Temperature	-65°C to +150°C
Voltage Range	
Vcc	-0.5 V to +4.0 V
RESET#, A9 and OE#	-0.5 V to +11.5 V
The other pins.	-0.5 V to Vcc +0.5 V
Output Short Circuit Current (less than one second)200 mA

Note:

1. Minimum voltage may undershoot to -2V during transition and for less than 20ns during transitions.
2. Maximum voltage may overshoot to Vcc+2V during transition and for less than 20ns during transitions.

OPERATING TEMPERATURE AND VOLTAGE

Commercial (C) Grade

Surrounding Temperature (T_A)

0°C to +70°C

Industrial (I) Grade

Surrounding Temperature (T_A)

-40°C to +85°C

Vcc Supply Voltages

Vcc range

+2.7 V to 3.6 V



ADVANCED INFORMATION

KH29LV160D T/B

DC CHARACTERISTICS

Symbol	Description	Min	Typ	Max	Remark
Iilk	Input Leak			± 1.0uA	
Iilk9	A9 Leak			35uA	A9=10.5V
Iolk	Output Leak			± 1.0uA	
Icr1	Read Current(5MHz)		7mA	12mA	CE#=Vil, OE#=Vih
Icr2	Read Current(1MHz)		2mA	4mA	CE#=Vil, OE#=Vih
Icw	Write Current		15mA	30mA	CE#=Vil, OE#=Vih, WE#=Vil
I _{sb}	Standby Current		5uA	15uA	V _{cc} =V _{cc max} , other pins disable
I _{sr}	Reset Current		5uA	15uA	V _{cc} =V _{ccmax} , Reset# enable, other pins disable
I _{sb} s	Sleep Mode Current		5uA	15uA	
I _{cp} 1	Accelerated Pgm Current, WP#/Acc pin(Word/Byte)		5mA	10mA	CE#=Vil, OE#=Vih
I _{cp} 2	Accelerated Pgm Current, V _{cc} pin,(Word/Byte)		15mA	30mA	CE#=Vil, OE#=Vih
V _{il}	Input Low Voltage	-0.5V		0.8V	
V _{ih}	Input High Voltage	0.7xV _{cc}		V _{cc} +0.3V	
V _{hv}	Very High Voltage for hardware Protect/Unprotect/Accelerated Program/Auto Select/Temporary Unprotect	9.5V		10.5V	
V _{ol}	Output Low Voltage			0.45V	I _{ol} =4.0mA
V _{oh} 1	Output High Voltage	0.85xV _{cc}			I _{oh} 1=-2mA
V _{oh} 2	Output High Voltage	V _{cc} -0.4V			I _{oh} 2=-100uA
V _{lko}	Low V _{cc} Lock-out Voltage	2.3V		2.5V	



ADVANCED INFORMATION

KH29LV160D T/B

SWITCHING TEST CIRCUIT

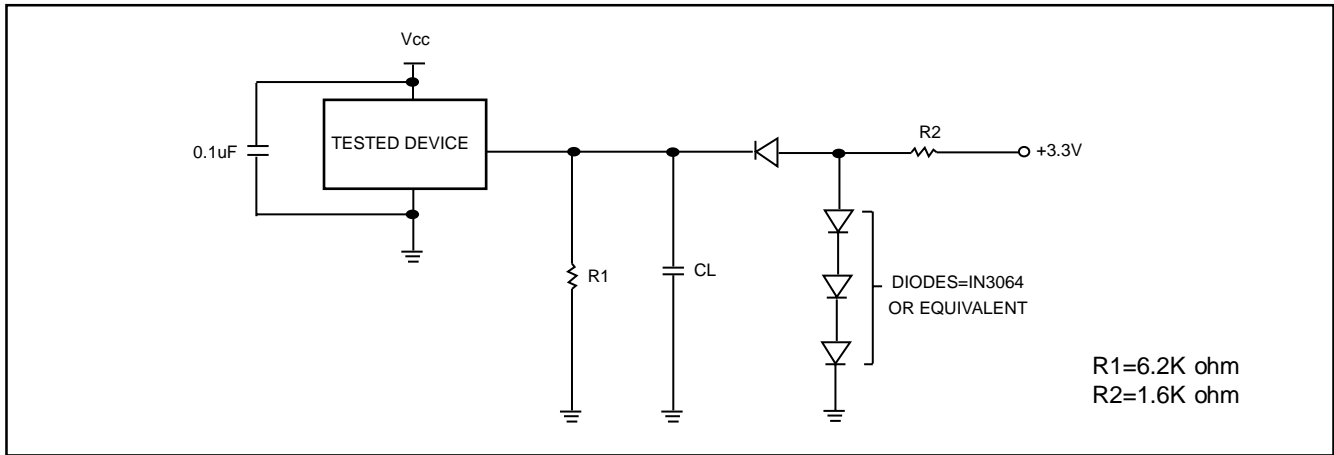

Test Condition

Output Load : 1 TTL gate

Output Load Capacitance, CL : 30pF(70ns)/100pF(90ns)

Rise/Fall Times : 5ns

In/Out reference levels : 1.5V

SWITCHING TEST WAVEFORM

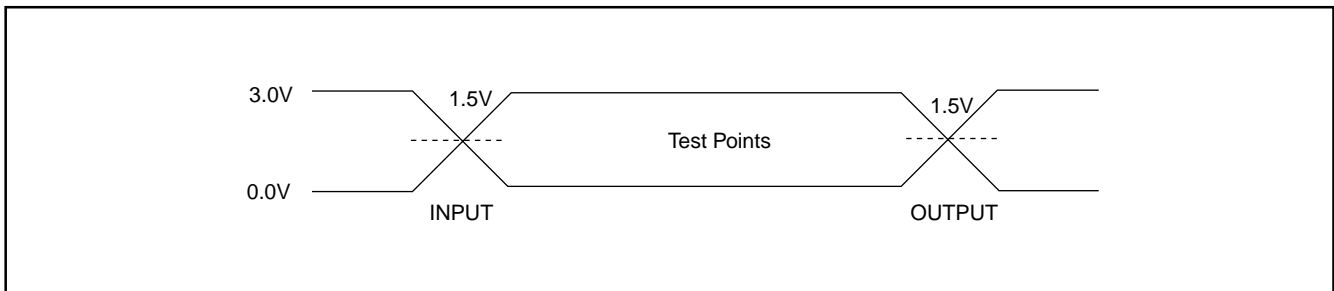



ADVANCED INFORMATION

KH29LV160D T/B

AC CHARACTERISTICS

Symbol	Description	Min	Typ	Max	Unit
Taa	Valid data output after address			70	ns
Tce	Valid data output after CE# low			70	ns
Toe	Valid data output after OE# low			30	ns
Tdf	Data output floating after OE# high			30	ns
Toh	Output hold time from the earliest rising edge of address, CE#, OE#	0			ns
Trc	Read period time	70			ns
Twc	Write period time	70			ns
Tcwc	Command write period time	70			ns
Tas	Address setup time	0			ns
Tah	Address hold time	45			ns
Tds	Data setup time	35			ns
Tdh	Data hold time	0			ns
Tvcs	Vcc setup time	200			us
Tcs	Chip enable Setup time	0			ns
Tch	Chip enable hold time	0			ns
Toes	Output enable setup time	0			ns
Toeh	Output enable hold time	Read	0		ns
Toeh		Toggle & Data# Polling	10		ns
Tws	WE# setup time	0			ns
Twh	WE# hold time	0			ns
Tcep	CE# pulse width	35			ns
Tceph	CE# pulse width high	30			ns
Twp	WE# pulse width	35			ns
Twph	WE# pulse width high	30			ns
Tbusy	Program/Erase active time by RY/BY#			90	ns
Tghwl	Read recover time before write	0			ns
Tghel	Read recover time before write	0			ns
Twhwh1	Program operation	Byte	9		us
Twhwh1	Program operation	Word	11		us
Twhwh1	Accelerated program operation		7	210	us
Twhwh2	Sector Erase Operation		0.7		sec
Tbal	Sector Add hold time			50	us



WRITE COMMAND OPERATION

Figure 1. COMMANDWRITE OPERATION

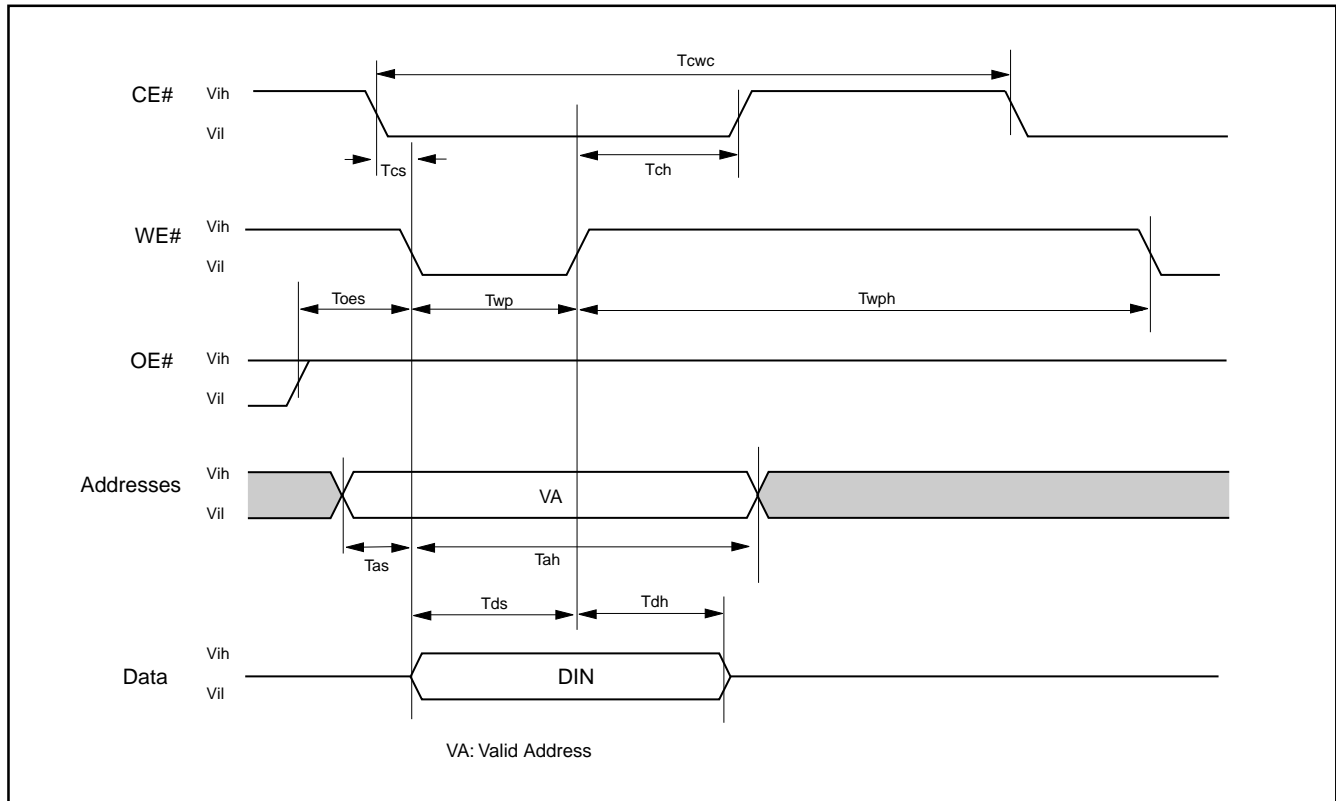



READ/RESET OPERATION

Figure 2. READTIMING WAVEFORM

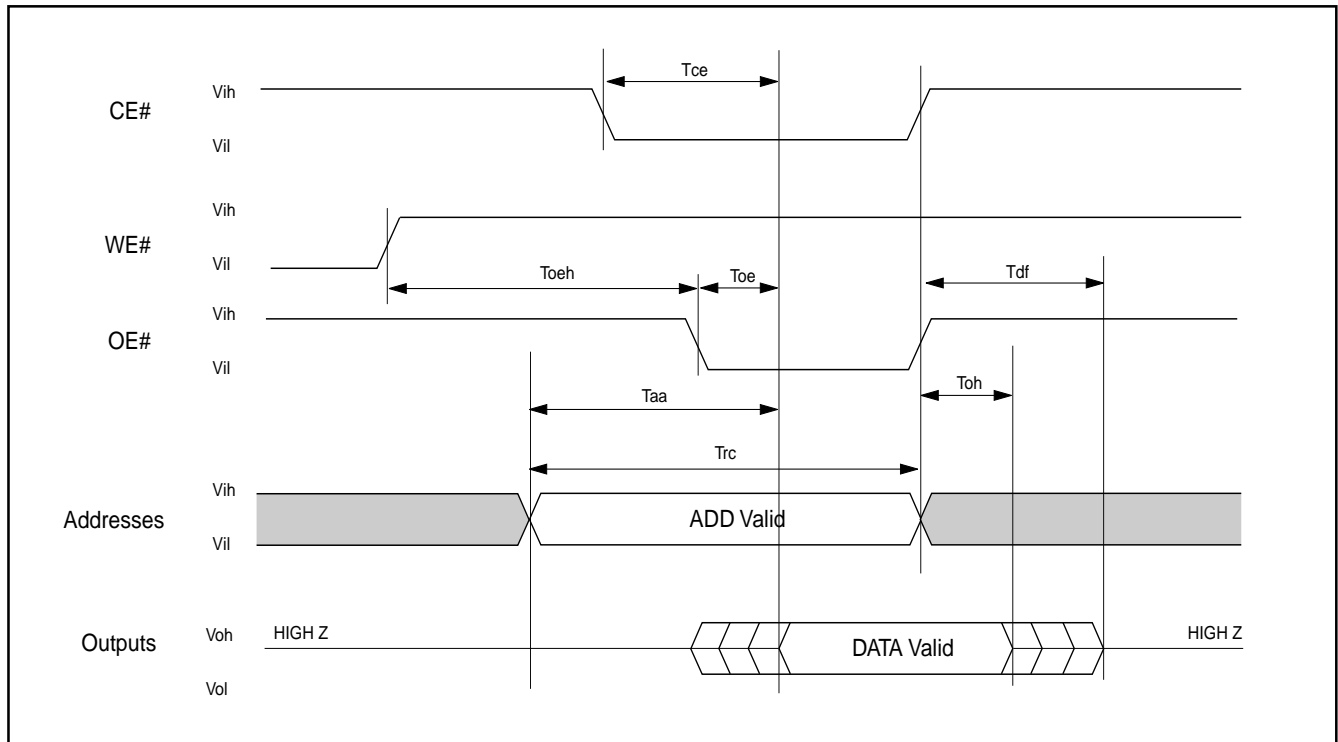



AC CHARACTERISTICS

Item	Description	Setup	Speed	Unit
Trp1	RESET# Pulse Width (During Automatic Algorithms)	MIN	10	us
Trp2	RESET# Pulse Width (NOT During Automatic Algorithms)	MIN	500	ns
Trh	RESET# High Time Before Read	MIN	70	ns
Trb1	RY/BY# Recovery Time (to CE#, OE# go low)	MIN	0	ns
Trb2	RY/BY# Recovery Time (to WE# go low)	MIN	50	ns
Tready1	RESET# PIN Low (During Automatic Algorithms) to Read or Write	MAX	20	us
Tready2	RESET# PIN Low (NOT During Automatic Algorithms) to Read or Write	MAX	500	ns

Figure 3. RESET# TIMING WAVEFORM

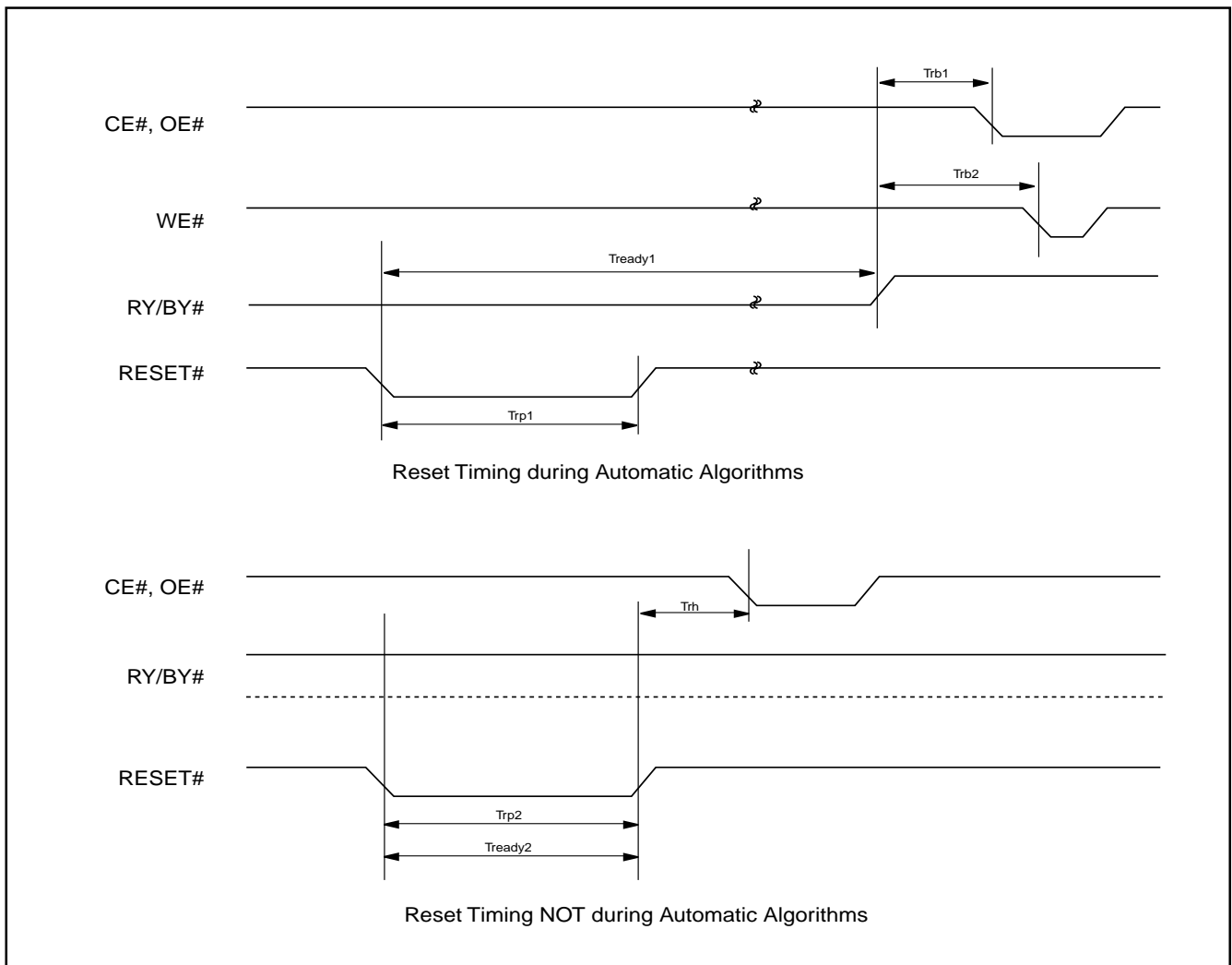



ERASE/PROGRAM OPERATION

Figure 4. AUTOMATIC CHIP ERASE TIMING WAVEFORM

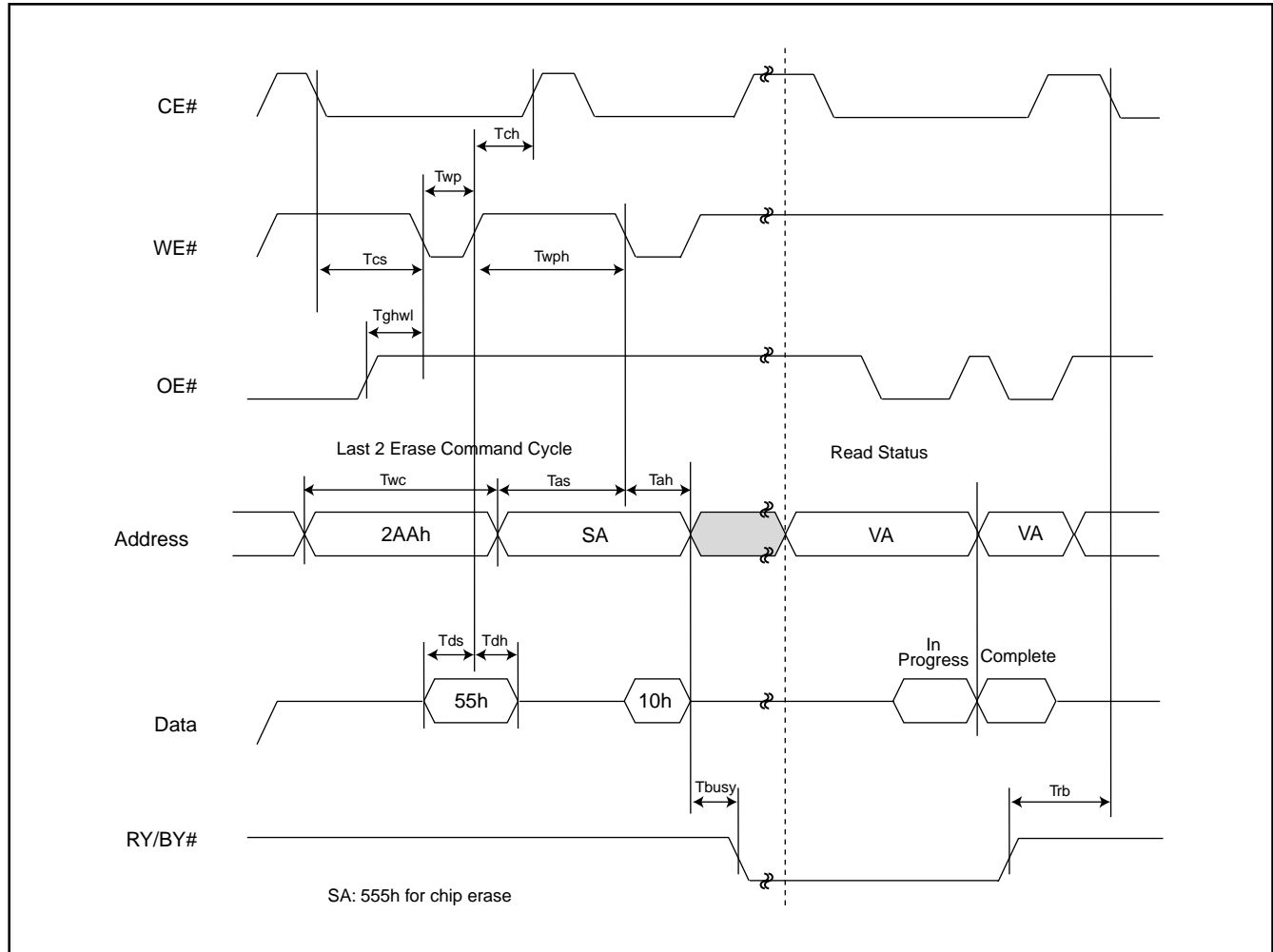



Figure 5. AUTOMATIC CHIP ERASE ALGORITHM FLOWCHART

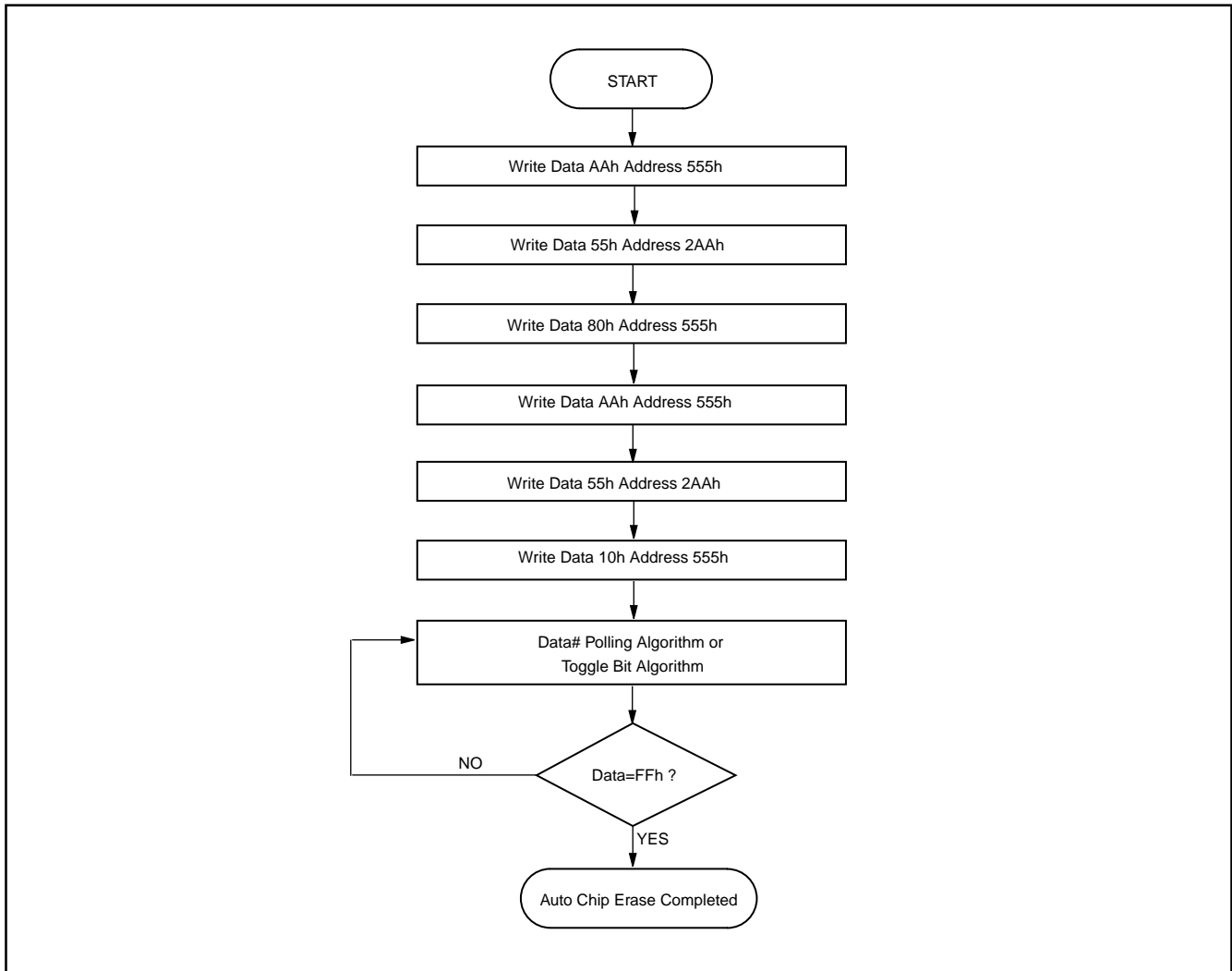



Figure 6. AUTOMATIC SECTOR ERASE TIMING WAVEFORM

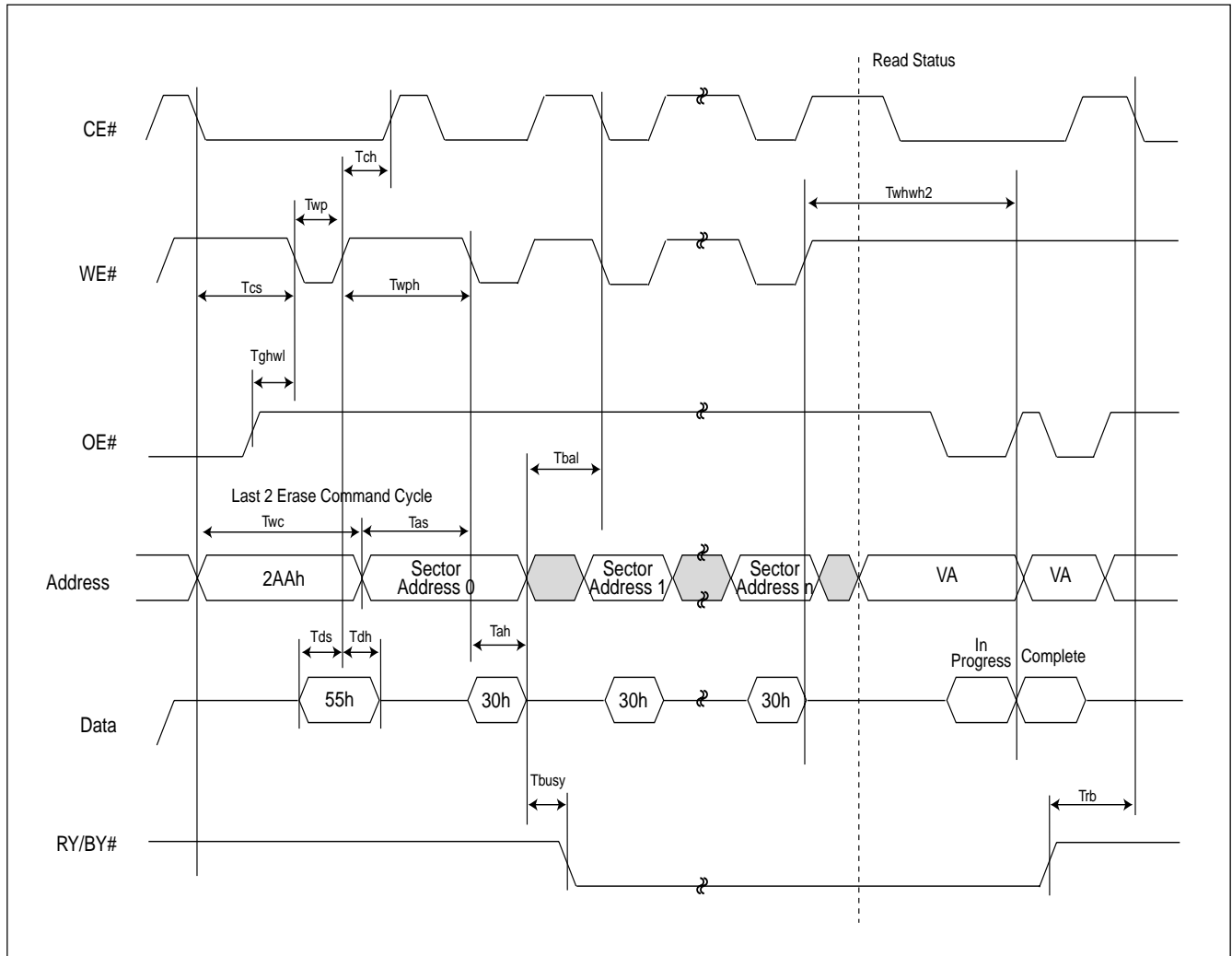



Figure 7. AUTOMATIC SECTOR ERASE ALGORITHM FLOWCHART

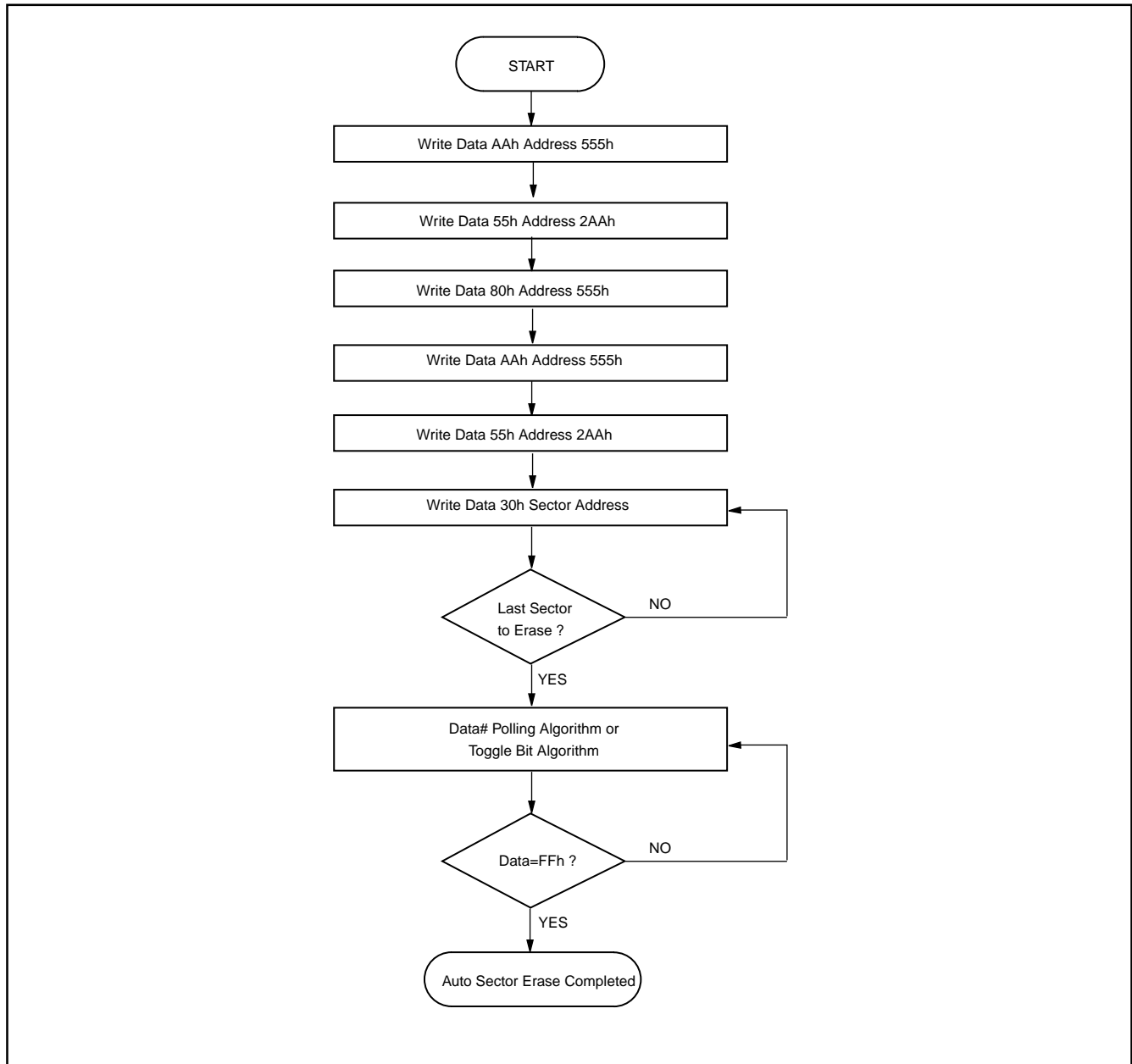
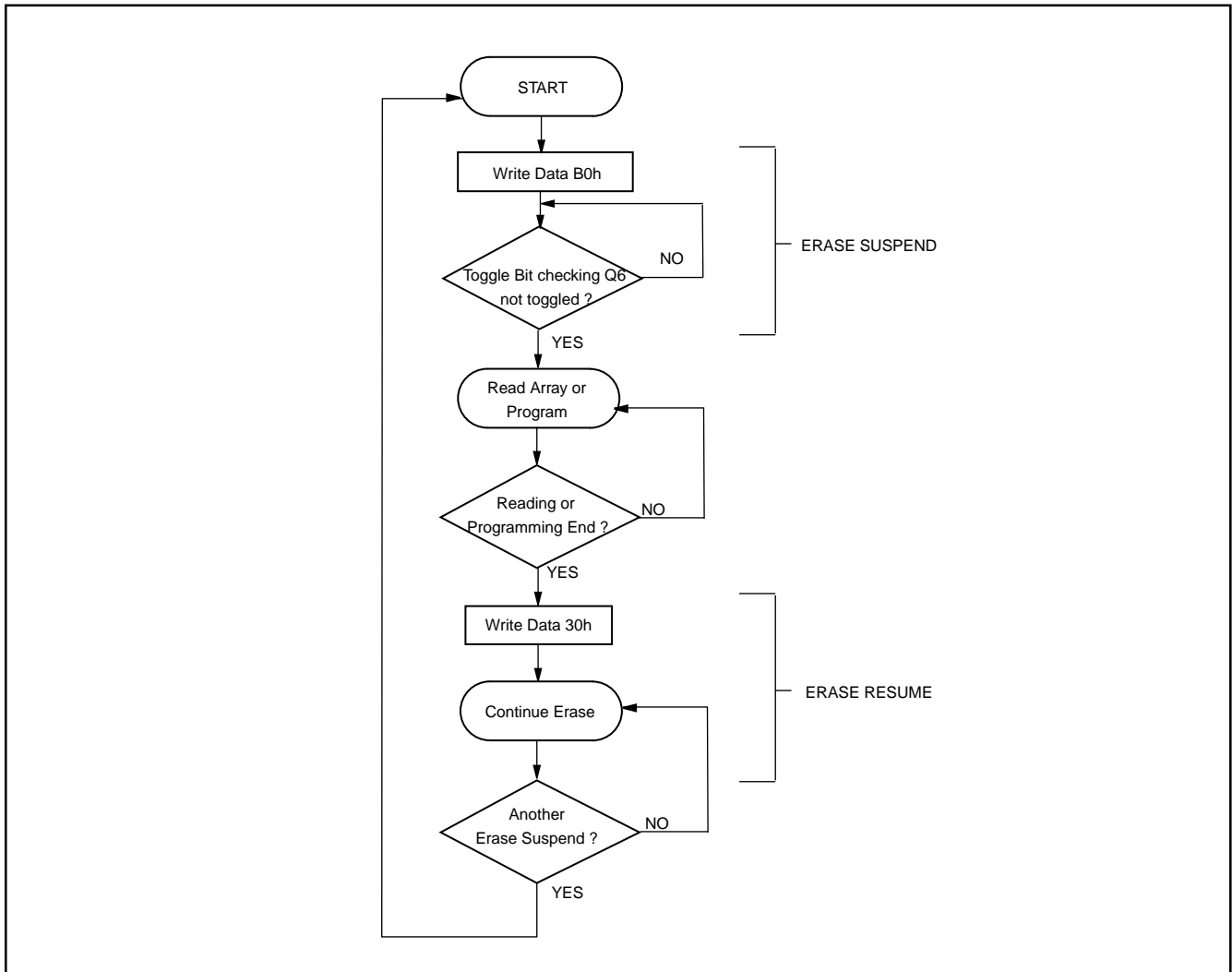



Figure 8. ERASE SUSPEND/RESUME FLOWCHART





ADVANCED INFORMATION

KH29LV160D T/B

Figure 9. AUTOMATIC PROGRAM TIMING WAVEFORM

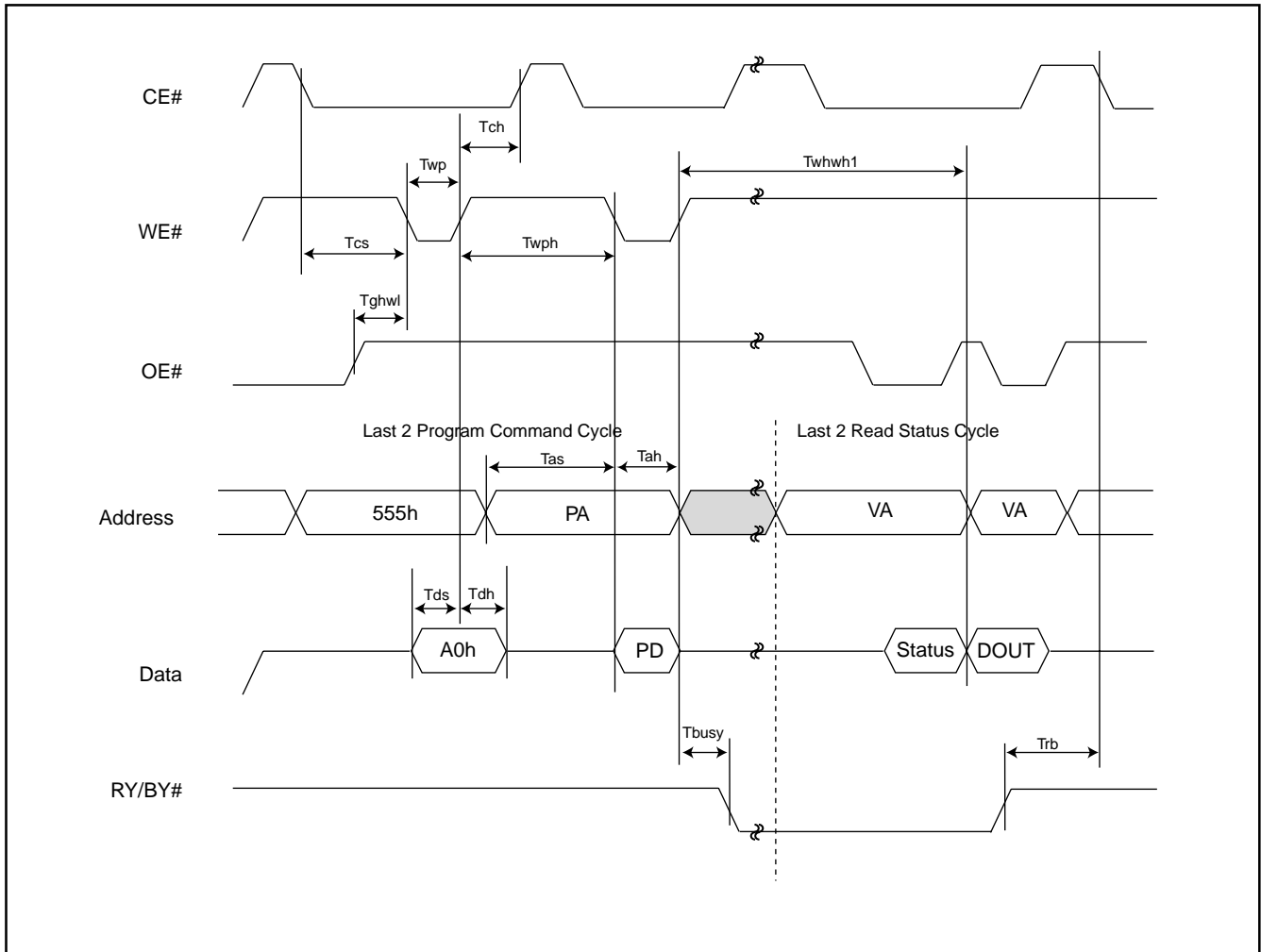
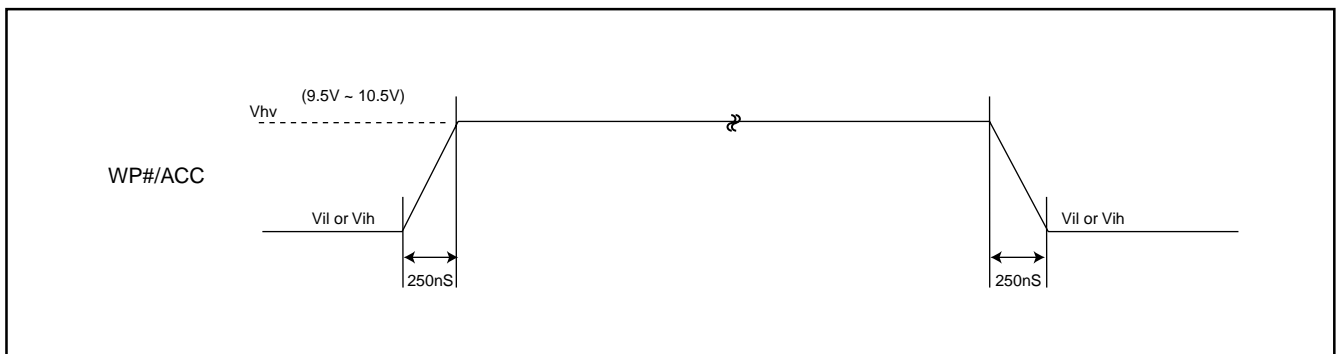

Figure 10. ACCELERATED PROGRAM TIMING DIAGRAM





ADVANCED INFORMATION

KH29LV160D T/B

Figure 11. CE# CONTROLLED WRITE TIMING WAVEFORM

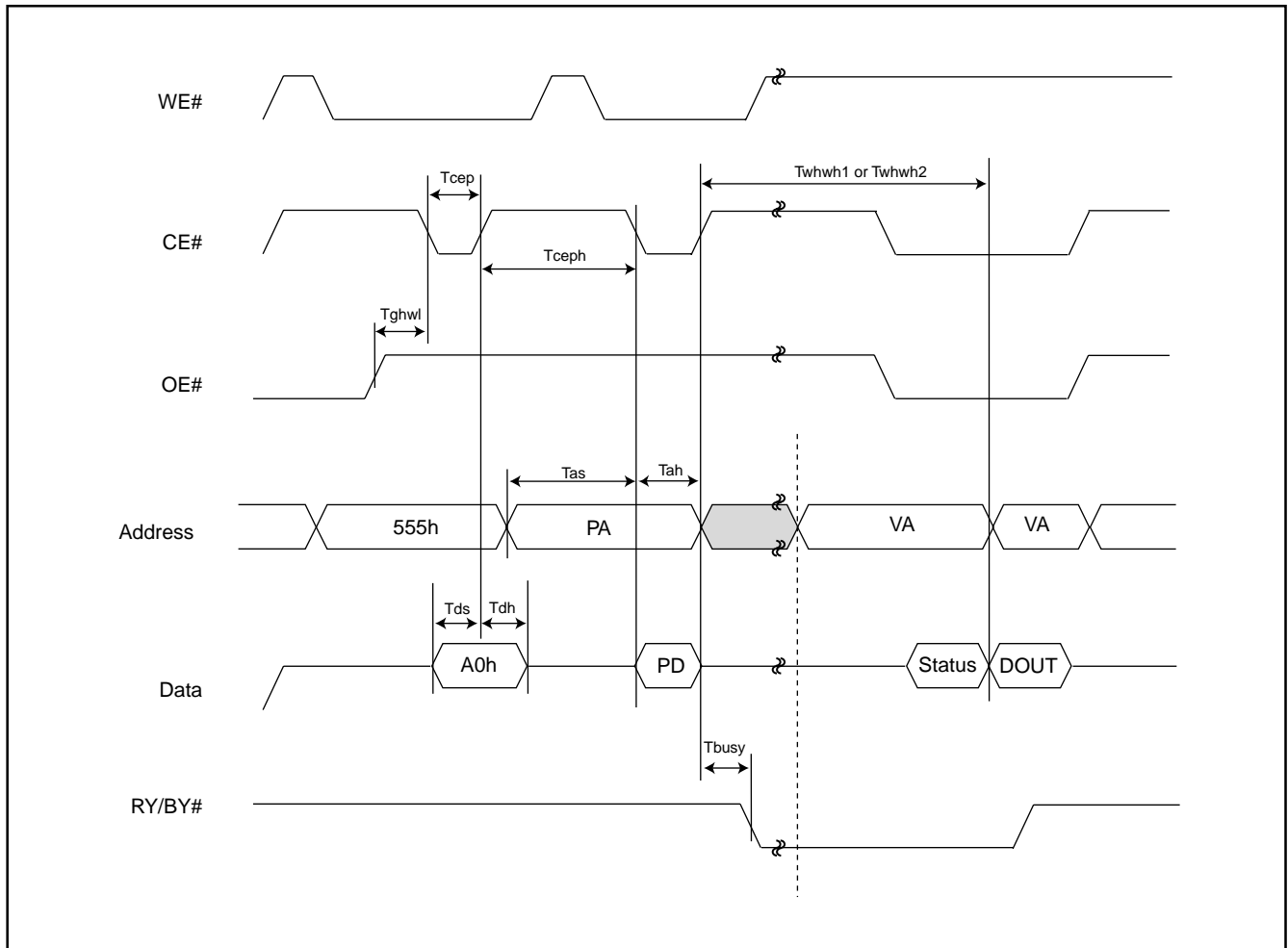
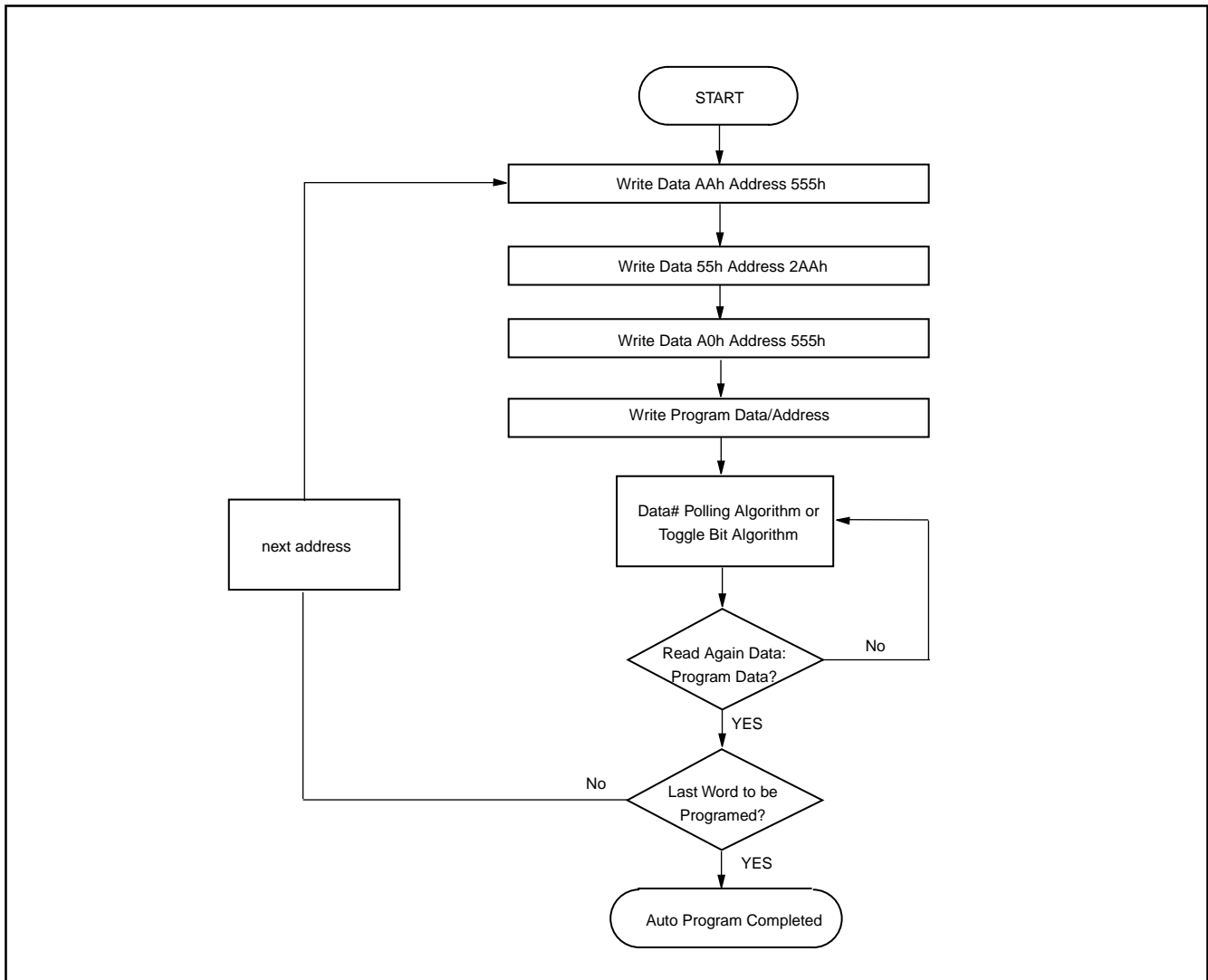



Figure 12. AUTOMATIC PROGRAMMING ALGORITHM FLOWCHART





SECTOR PROTECT/CHIP UNPROTECT

Figure 13. SECTOR PROTECT/CHIP UNPROTECT WAVEFORM (RESET# Control)

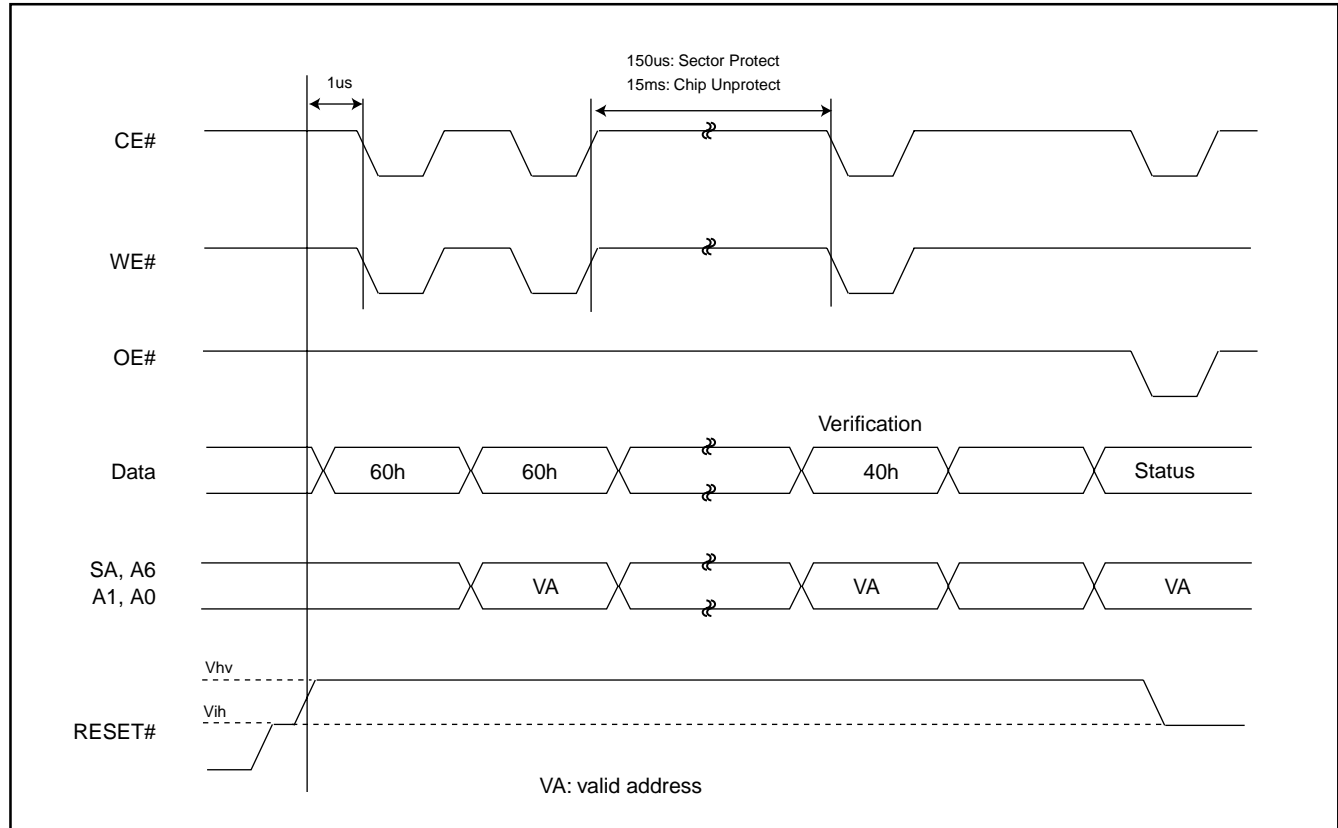



Figure 14. IN-SYSTEM SECTOR PROTECT WITH RESET# = Vhv

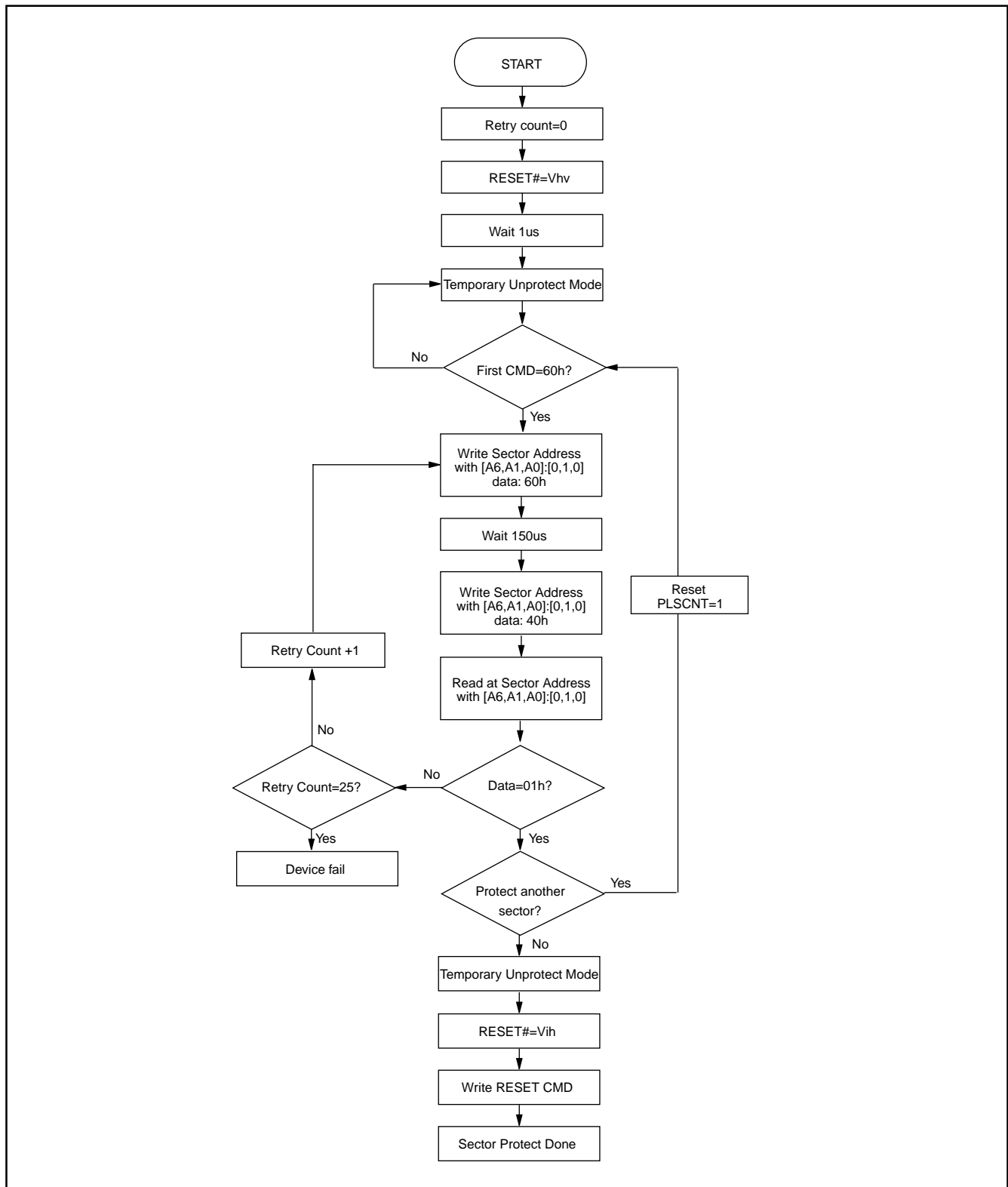
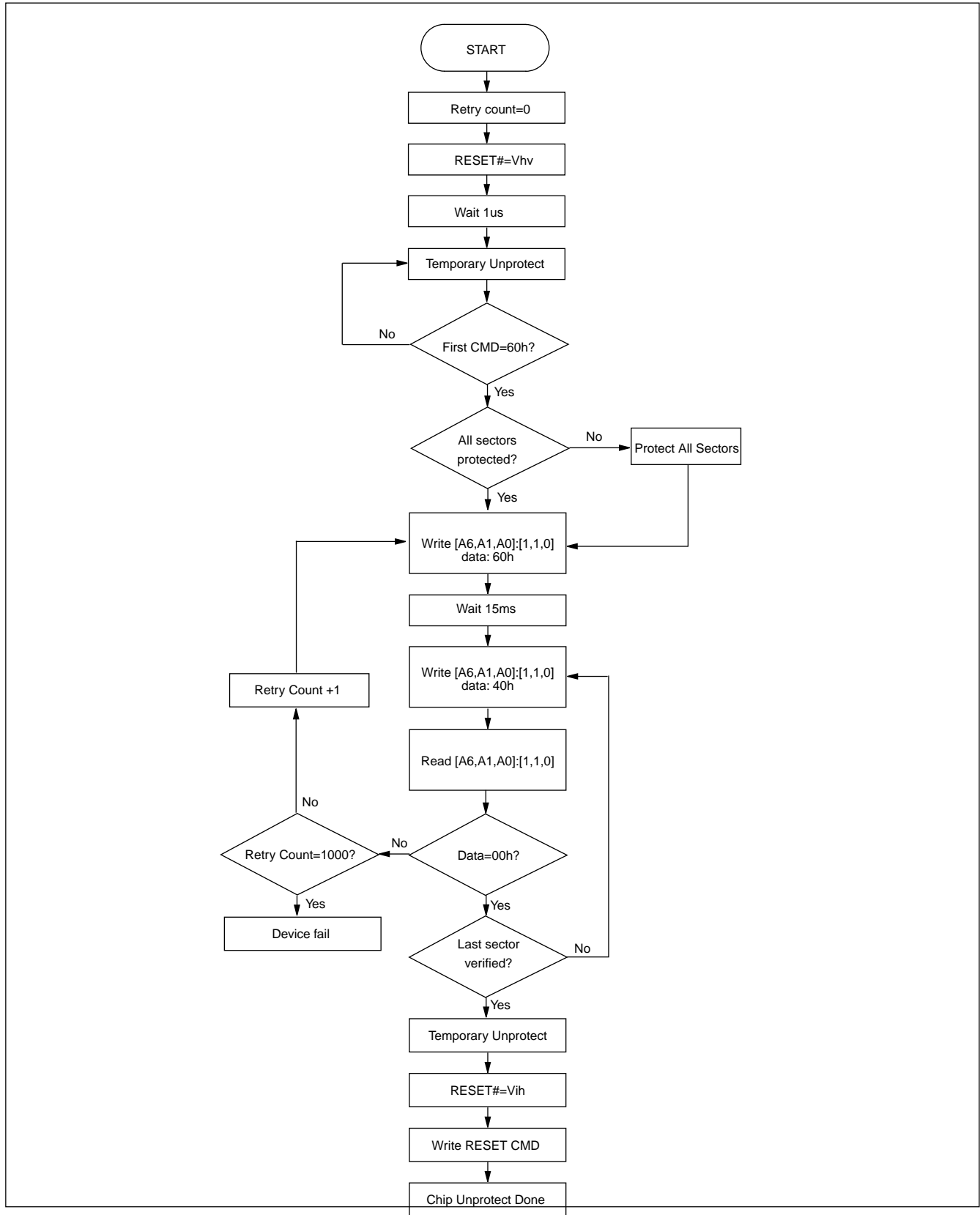



Figure 15. CHIP UNPROTECT ALGORITHMS WITH RESET# = Vhv





ADVANCED INFORMATION

KH29LV160D T/B

Table 5. TEMPORARY SECTOR UNPROTECT

Parameter	Alt	Description	Condition	Speed	Unit
Trpvhh	Tvidr	RESET# Rise Time to Vhv and Vhv Fall Time to RESET#	MIN	500	ns
Tvhhwl	Trsp	RESET# Vhv to WE# Low	MIN	4	us

Figure 16. TEMPORARY SECTOR UNPROTECT WAVEFORM

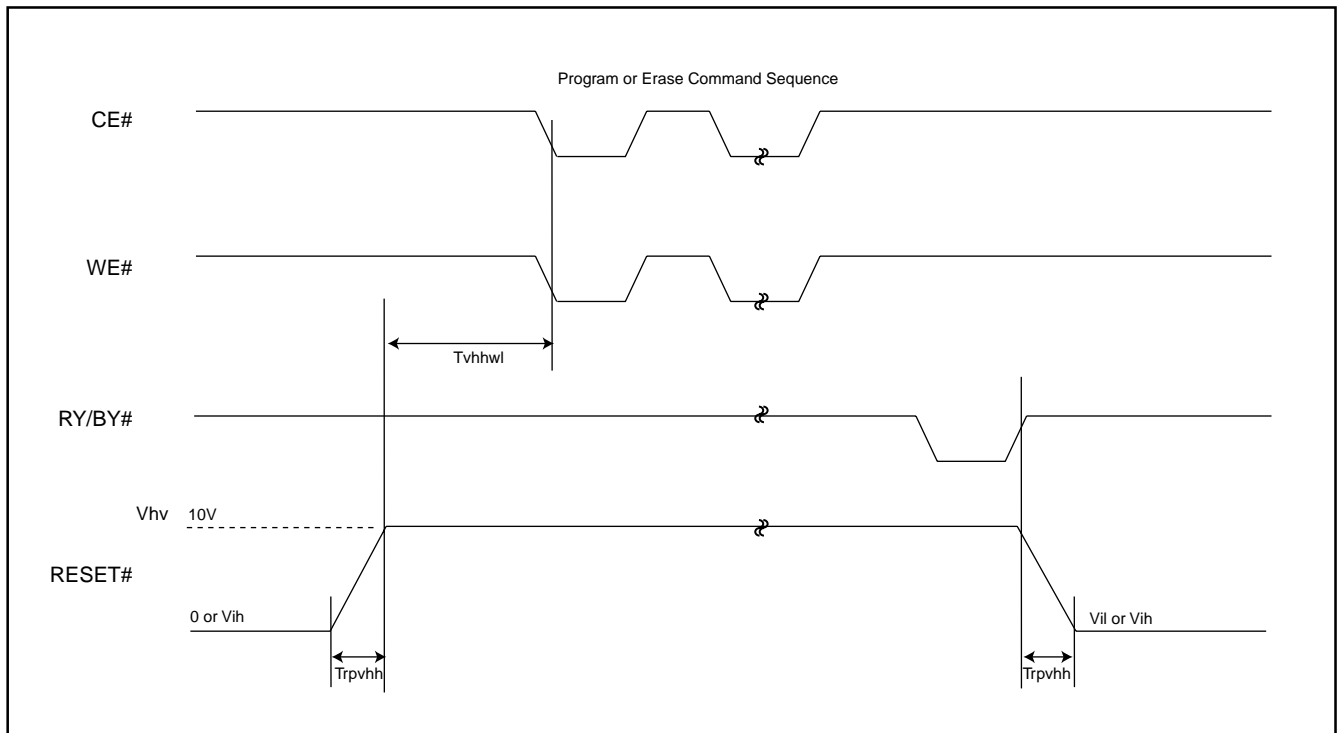
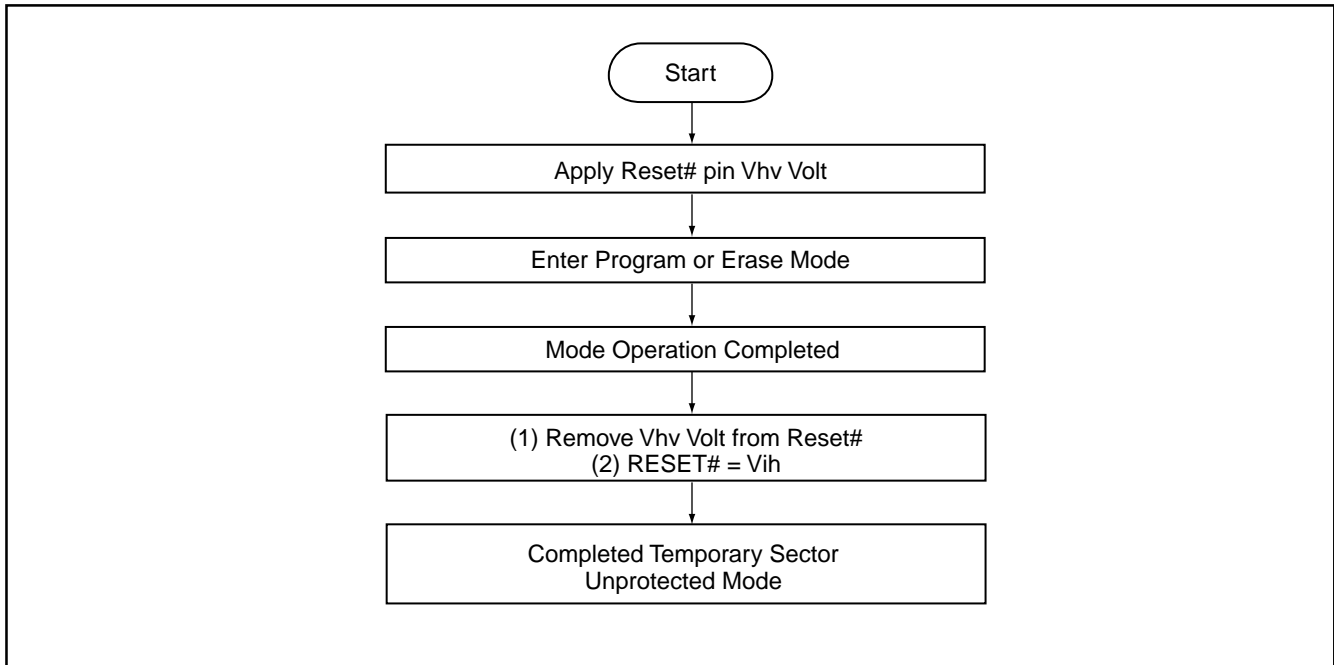



Figure 17. TEMPORARY SECTOR UNPROTECT FLOWCHART



Notes:

1. Temporary unprotect all protected sectors $V_{hv}=9.5\sim 10.5V$.
2. After leaving temporary unprotect mode, the previously protected sectors are again protected.



ADVANCED INFORMATION

KH29LV160D T/B

Figure 18. SILICON ID READTIMING WAVEFORM

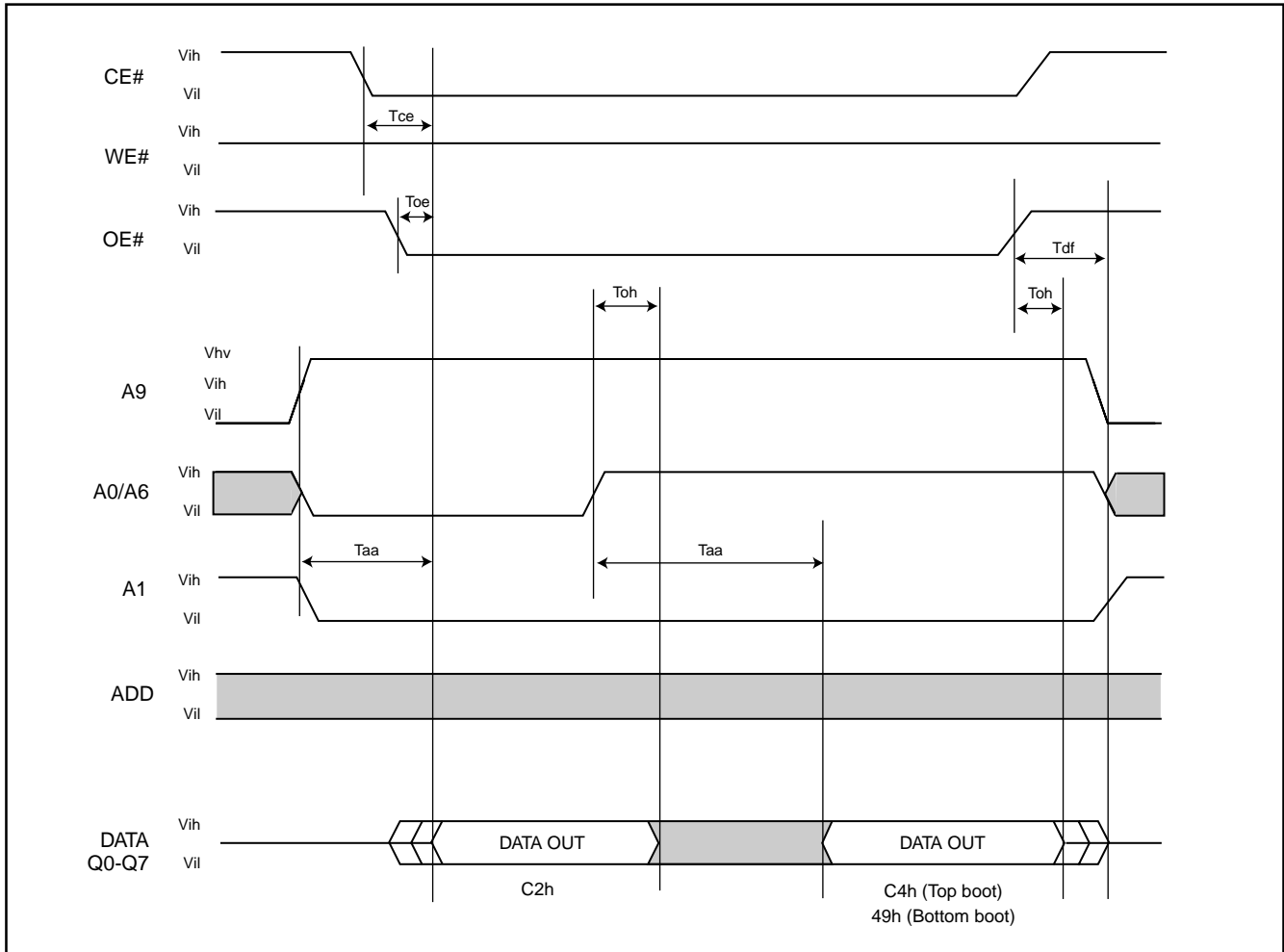



WRITE OPERATION STATUS

Figure 19. DATA# POLLING TIMING WAVEFORM (DURING AUTOMATIC ALGORITHM)

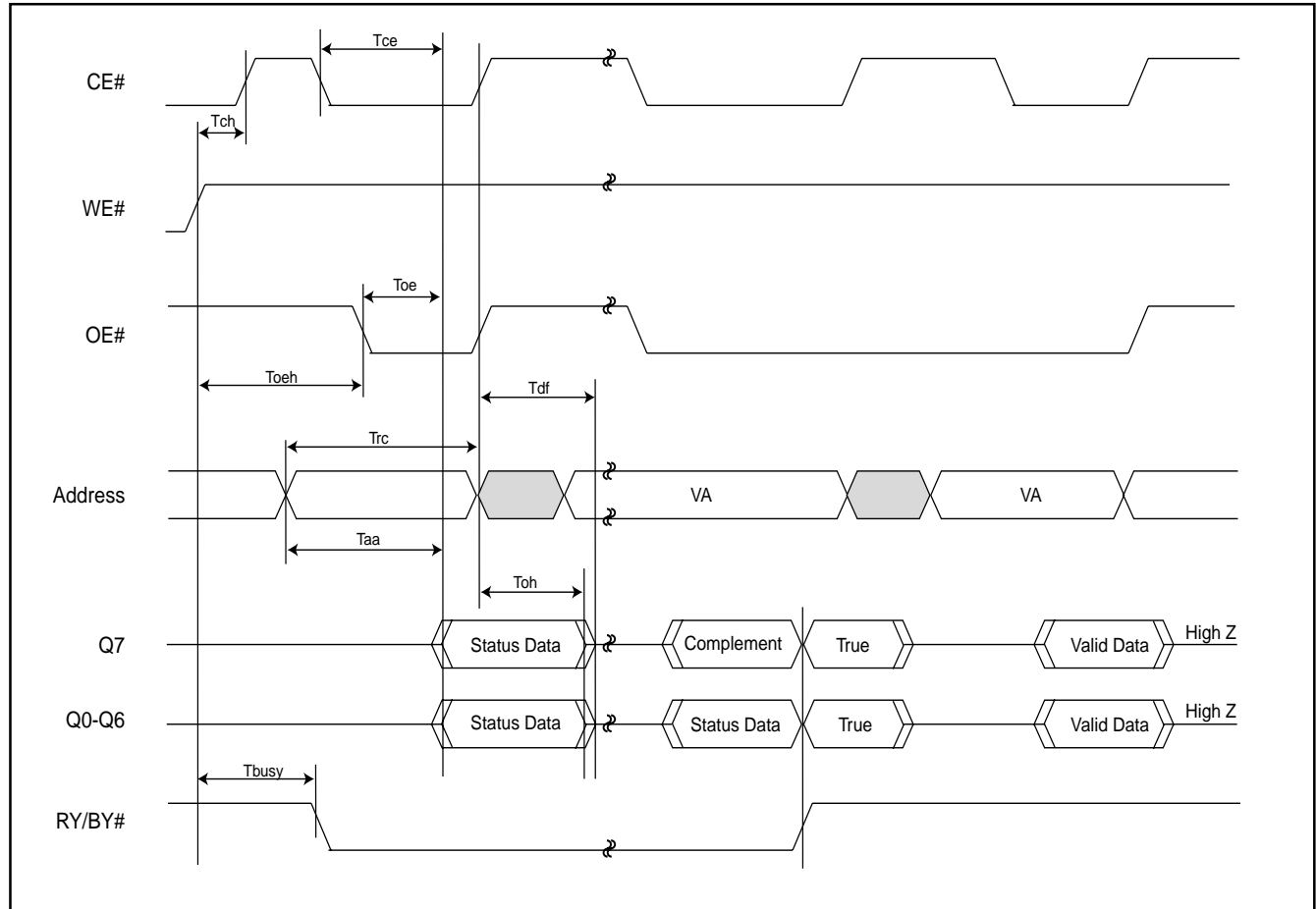
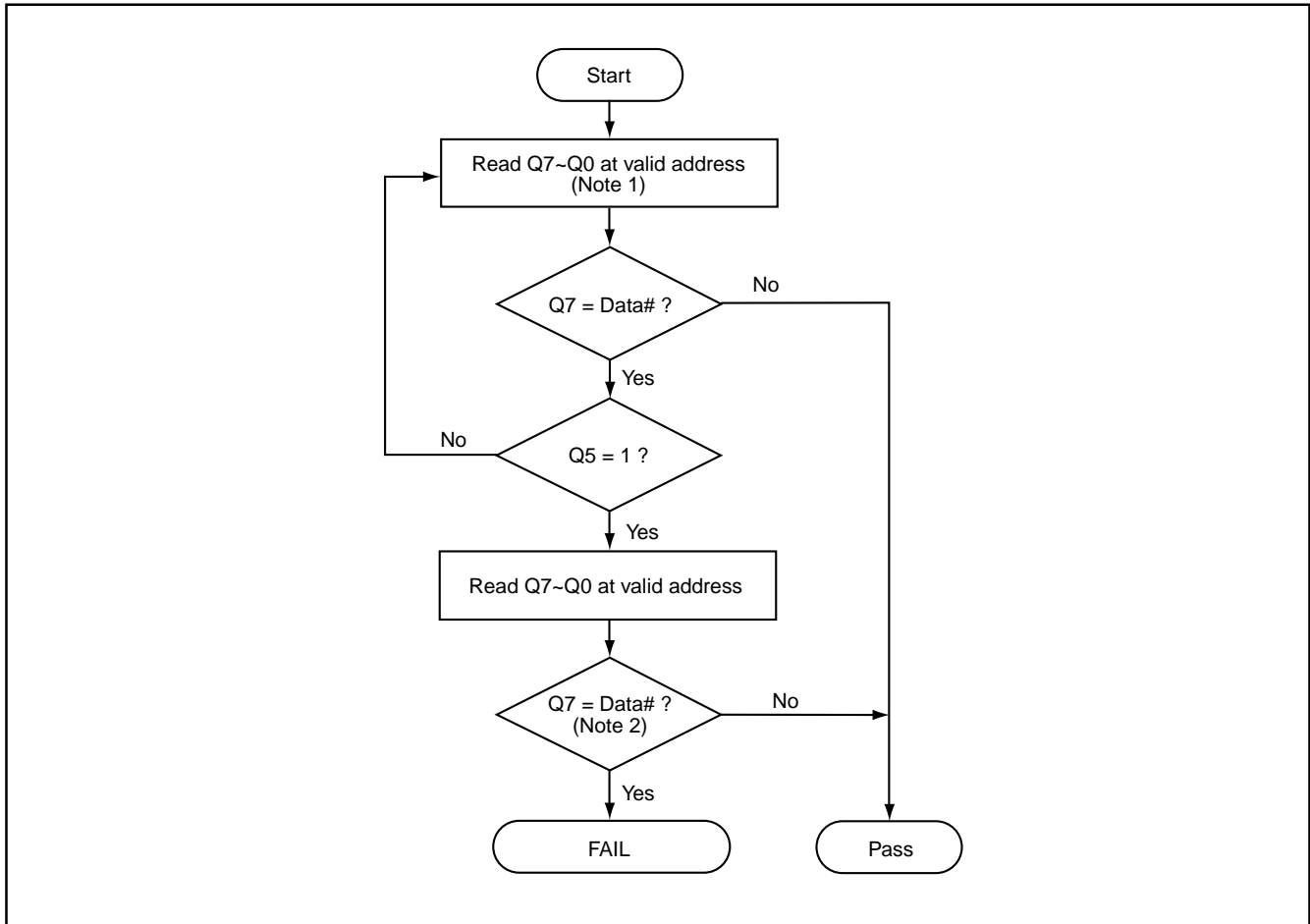



Figure 20. DATA# POLLING ALGORITHM



Notes:

1. For programming, valid address means program address.
For erasing, valid address means erase sectors address.
2. Q7 should be rechecked even Q5="1" because Q7 may change simultaneously with Q5.



ADVANCED INFORMATION

KH29LV160D T/B

Figure 21. TOGGLE BIT TIMING WAVEFORM (DURING AUTOMATIC ALGORITHM)

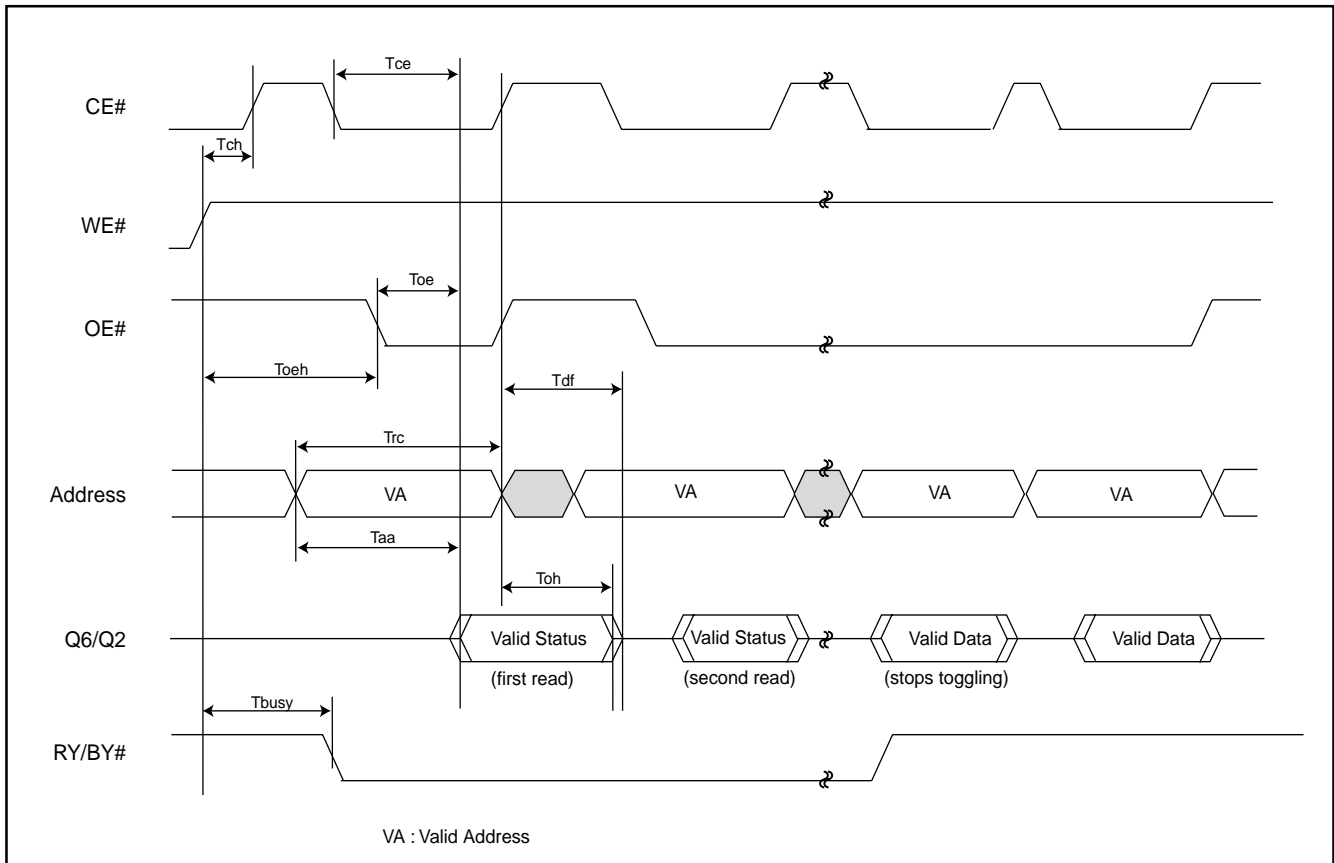
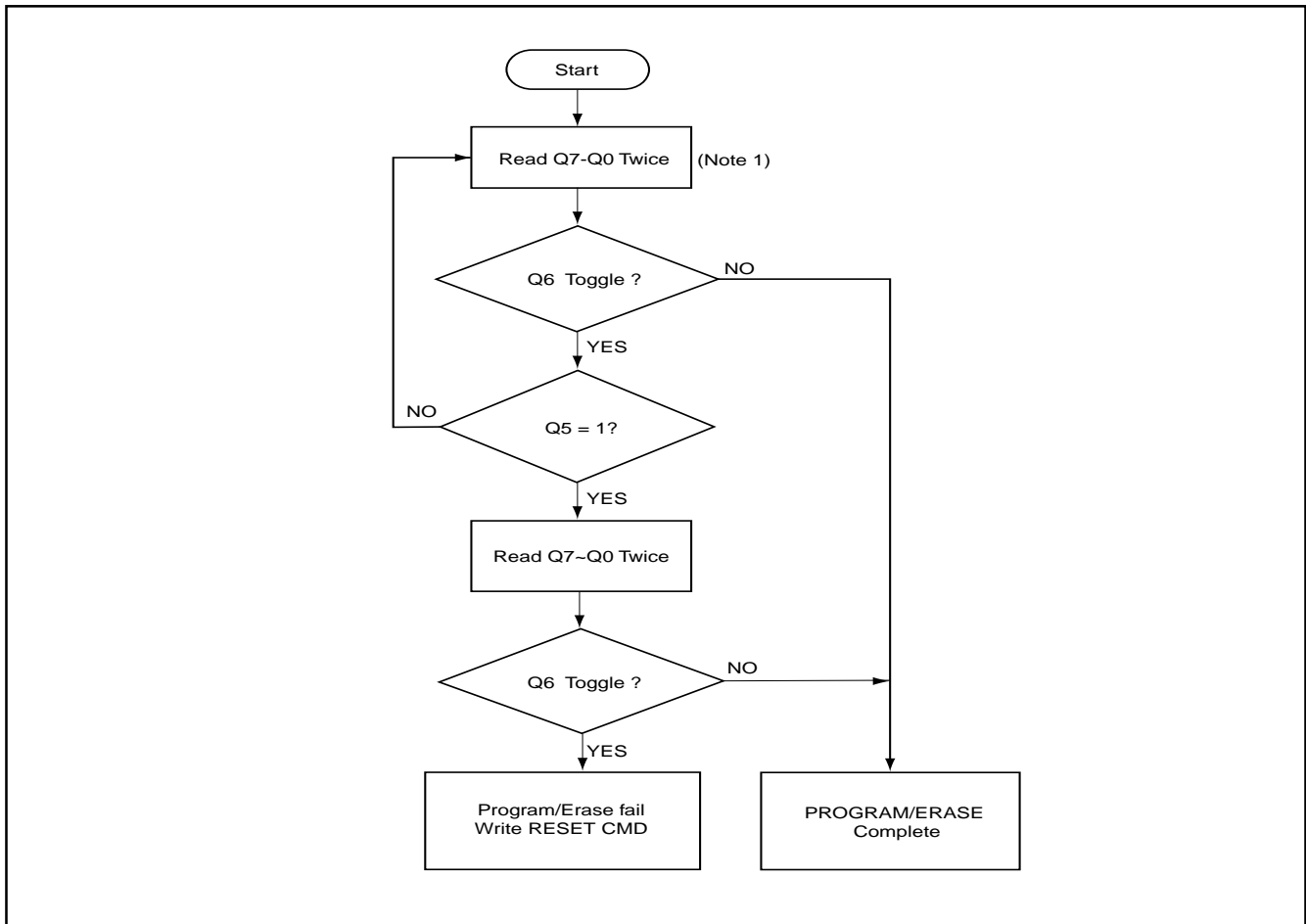



Figure 22. TOGGLE BIT ALGORITHM



Notes:

1. Read toggle bit twice to determine whether or not it is toggling.
2. Recheck toggle bit because it may stop toggling as Q5 changes to "1".



AC CHARACTERISTICS

WORD/BYTE CONFIGURATION (BYTE#)

Parameter	Description		Speed Options		Unit
			-70	-90	
Telf/Telfh	CE# to BYTE# from L/H	MAX	5	5	ns
Tflqz	BYTE# from L to Output Hiz	MAX	25	30	ns
Tfhqv	BYTE# from H to Output Active	MIN	70	90	ns

Figure 23. BYTE# TIMING WAVEFORM FOR READ OPERATIONS (BYTE# switching from byte mode to word mode)

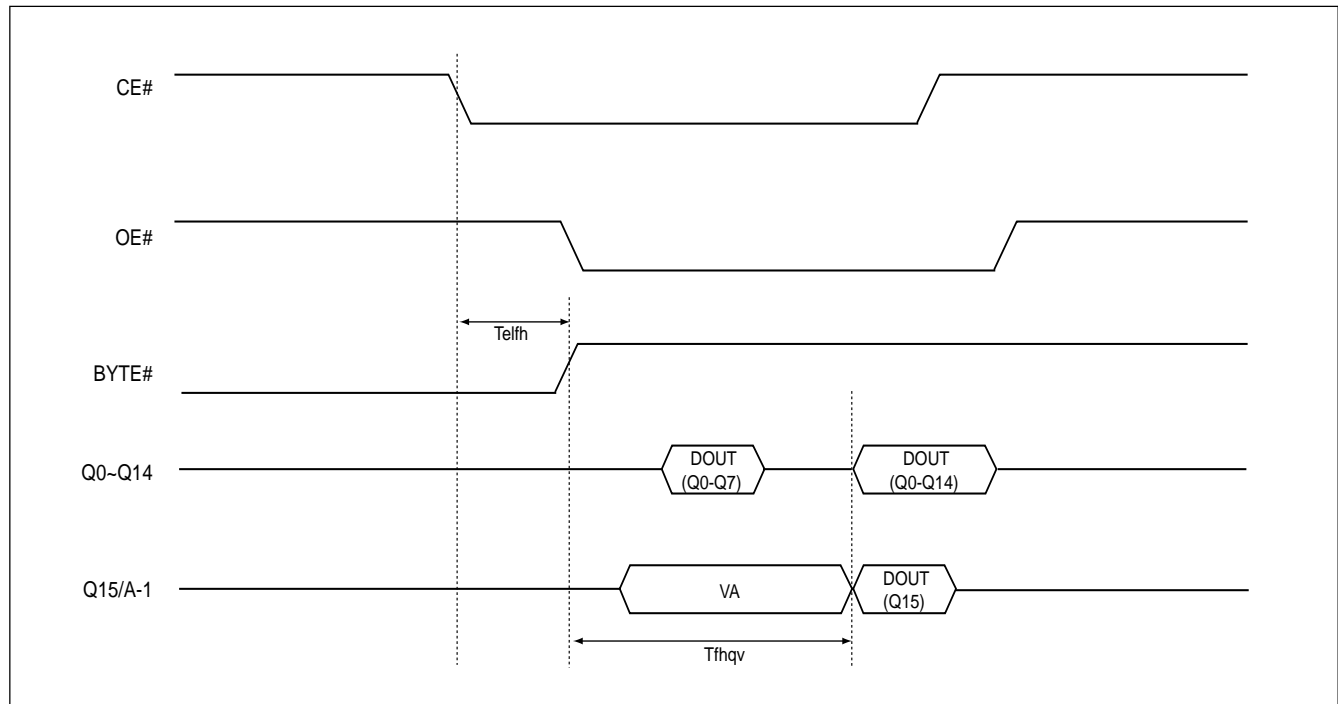



RECOMMENDED OPERATING CONDITIONS

At Device Power-Up

AC timing illustrated in Figure A is recommended for the supply voltages and the control signals at device power-up. If the timing in the figure is ignored, the device may not operate correctly.

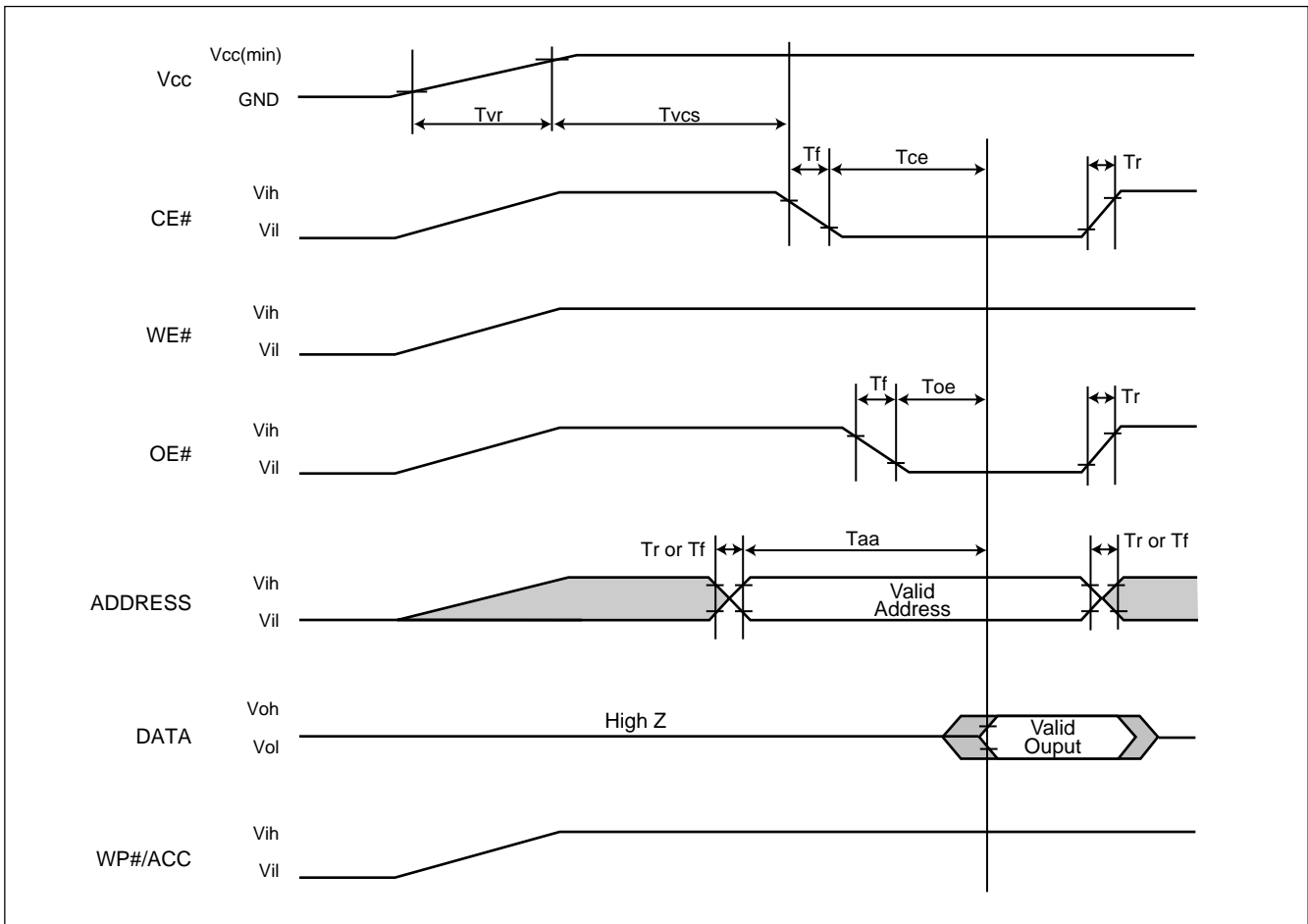

Figure A. AC Timing at Device Power-Up

Symbol	Parameter	Min.	Max.	Unit
Tvr	Vcc Rise Time	20	500000	us/V
Tr	Input Signal Rise Time		20	us/V
Tf	Input Signal Fall Time		20	us/V
Tvcs	Vcc Setup Time	200		us



ADVANCED INFORMATION

KH29LV160D T/B

ERASE AND PROGRAMMING PERFORMANCE

PARAMETER		LIMITS			UNITS
		MIN.	TYP.	MAX.	
Chip Erase Time			15	32	sec
Sector Erase Time			0.7	2	sec
Erase/Program Cycles			100,000		Cycles
Chip Programming Time	Byte Mode		18	54	sec
	Word Mode		12	36	sec
Word Program Time			11	360	us
Byte Programming Time			9	300	us
Accelerated Program Time			7	210	us

Notes:

1. Erase/Program cycle comply with JEDEC JESD-47E & A117A standard.

LATCH-UP CHARACTERISTICS

	MIN.	MAX.
Input voltage difference with GND on all pins except I/O pins	-1.0V	11.5V
Input voltage difference with GND on all I/O pins	-1.0V	1.5 x Vcc
Vcc Current	-100mA	+100mA
All pins included except Vcc. Test conditions: Vcc = 3.0V, one pin per testing		

TSOP PIN CAPACITANCE

Parameter Symbol	Parameter Description	Test Set	TYP	MAX	UNIT
CIN2	Control Pin Capacitance	VIN=0	7.5	9	pF
COUT	Output Capacitance	VOUT=0	8.5	12	pF
CIN	Input Capacitance	VIN=0	6	7.5	pF



ADVANCED INFORMATION
KH29LV160D T/B

ORDERING INFORMATION

PART NO.	ACCESS TIME (ns)	Ball Pitch/ Ball Size	PACKAGE	Remark
KH29LV160DTTC-70G	70		48 Pin TSOP (Normal Type)	PB free
KH29LV160DBTC-70G	70		48 Pin TSOP (Normal Type)	PB free



ADVANCED INFORMATION

KH29LV160D T/B

PART NAME DESCRIPTION

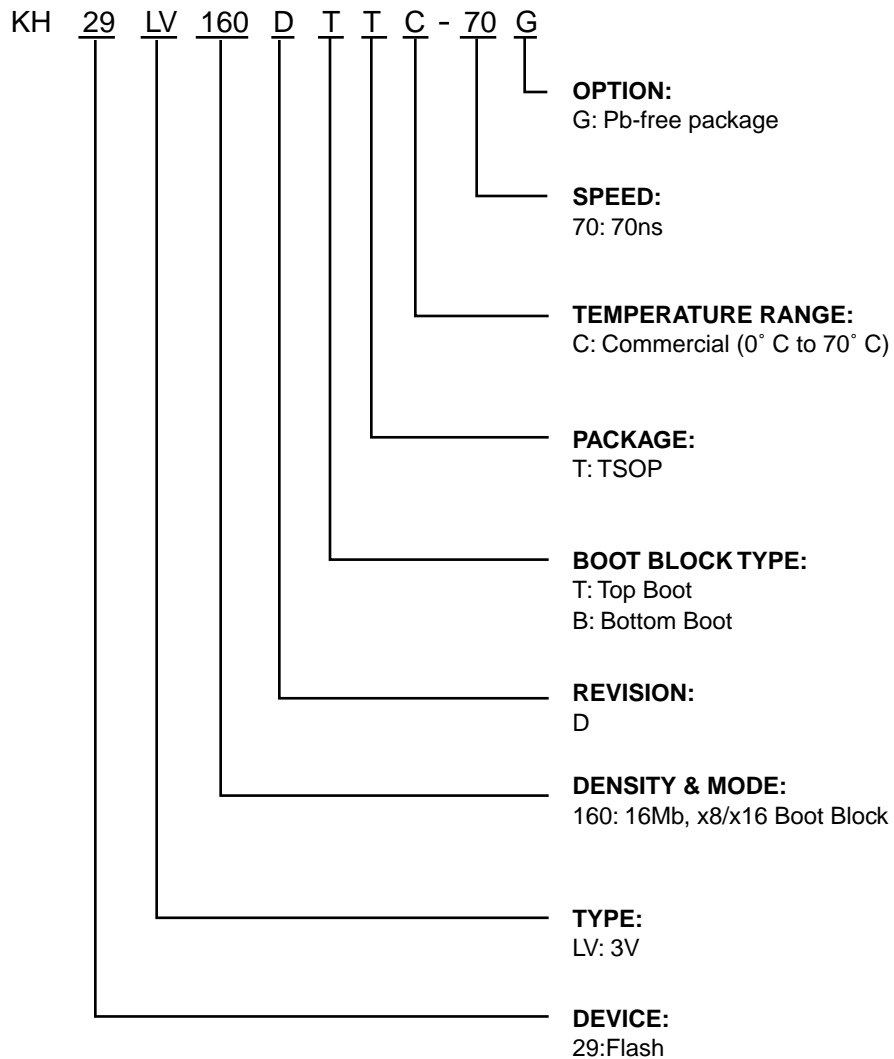



ADVANCED INFORMATION

KH29LV160D T/B

PACKAGE INFORMATION

Title: Package Outline for TSOP(I) 48L (12X20mm)NORMAL FORM

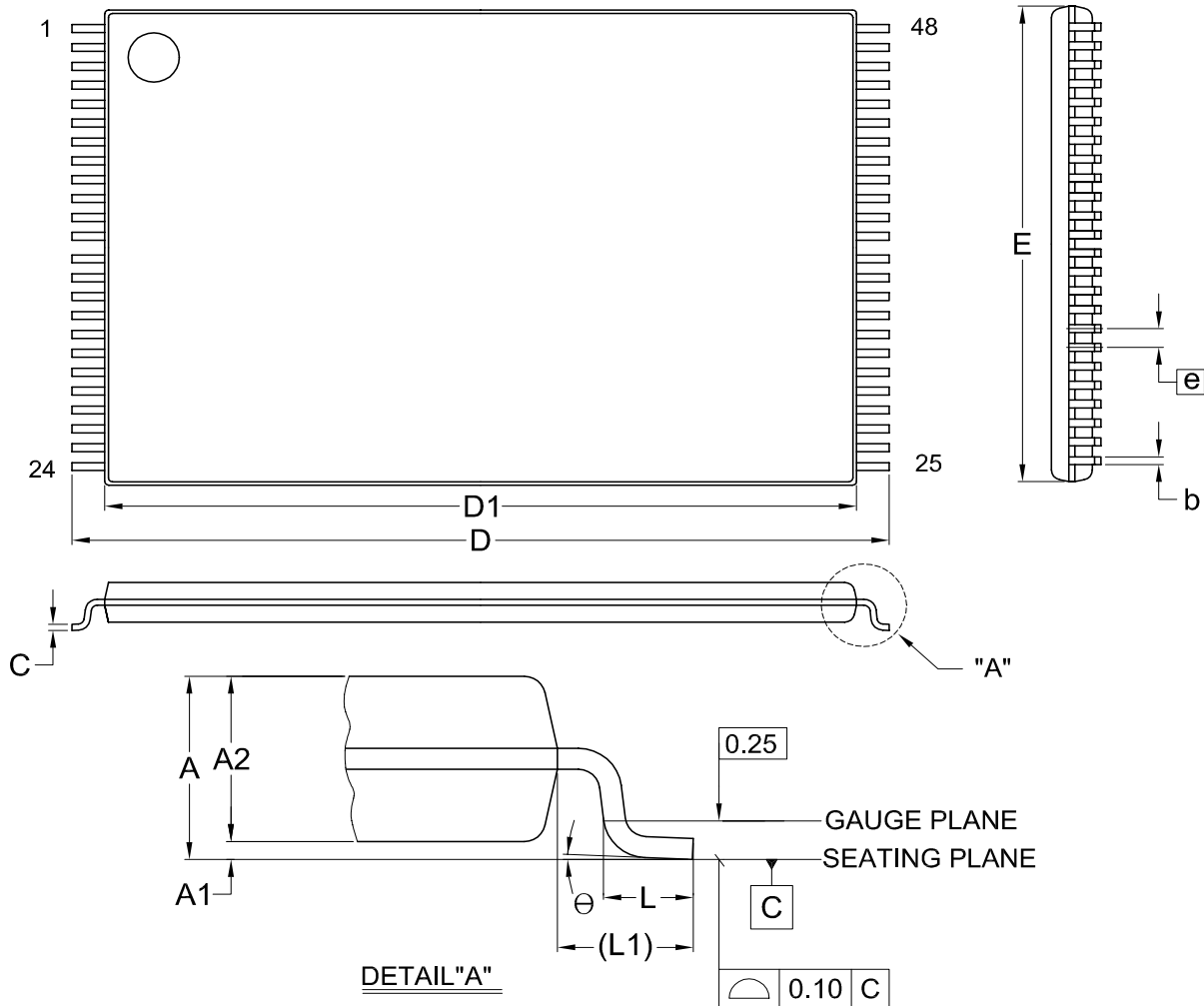

Dimensions (inch dimensions are derived from the original mm dimensions)

SYMBOL		A	A1	A2	b	C	D	D1	E	e	L	L1	θ
mm	Min.	---	0.05	0.95	0.17	0.10	19.80	18.30	11.90	---	0.50	0.70	0
	Nom.	---	0.10	1.00	0.20	0.13	20.00	18.40	12.00	0.50	0.60	0.80	5
	Max.	1.20	0.15	1.05	0.27	0.21	20.20	18.50	12.10	---	0.70	0.90	8
Inch	Min.	---	0.002	0.037	0.007	0.004	0.780	0.720	0.469	---	0.020	0.028	0
	Nom.	---	0.004	0.039	0.008	0.005	0.787	0.724	0.472	0.020	0.024	0.031	5
	Max.	0.047	0.006	0.041	0.011	0.008	0.795	0.728	0.476	---	0.028	0.035	8

DWG.NO.	REVISION	REFERENCE			ISSUE DATE
		JEDEC	EIAJ		
6110-1607	8	MO-142			2007/08/03



ADVANCED INFORMATION
KH29LV160D T/B

REVISION HISTORY

Revision No.	Description	Page	Date
0.01	1. Revised Vhv data from 10.5V~11.5V to 9.5V~10.5V	P28,39,45,46	MAY/20/2008



Macronix's products are not designed, manufactured, or intended for use for any high risk applications in which the failure of a single component could cause death, personal injury, severe physical damage, or other substantial harm to persons or property, such as life-support systems, high temperature automotive, medical, aircraft and military application. Macronix and its suppliers will not be liable to you and/or any third party for any claims, injuries or damages that may be incurred due to use of Macronix's products in the prohibited applications.

MACRONIX INTERNATIONAL CO., LTD.

Headquarters

Macronix, Int'l Co., Ltd.
16, Li-Hsin Road, Science Park,
Hsinchu, Taiwan, R.O.C.
Tel: +886-3-5786688
Fax: +886-3-5632888

Macronix America, Inc.

680 North McCarthy Blvd.
Milpitas, CA 95035, U.S.A.
Tel: +1-408-262-8887
Fax: +1-408-262-8810
Email: sales.northamerica@macronix.com

Macronix Japan Cayman Islands Ltd.

NKF Bldg. 5F, 1-2 Higashida-cho,
Kawasaki-ku Kawasaki-shi,
Kanagawa Pref. 210-0005, Japan
Tel: +81-44-246-9100
Fax: +81-44-246-9105

Macronix (Hong Kong) Co., Limited.

702-703, 7/F, Building 9,
Hong Kong Science Park,
5 Science Park West Avenue, Sha Tin, N.T.
Tel: +86-852-2607-4289
Fax: +86-852-2607-4229

[http : //www.macronix.com](http://www.macronix.com)

Taipei Office

Macronix, Int'l Co., Ltd.
19F, 4, Min-Chuan E. Road, Sec. 3,
Taipei, Taiwan, R.O.C.
Tel: +886-2-2509-3300
Fax: +886-2-2509-2200

Macronix Europe N.V.

Koningin Astridlaan 59, Bus 1
1780 Wemmel Belgium
Tel: +32-2-456-8020
Fax: +32-2-456-8021

Singapore Office

Macronix Pte. Ltd.
1 Marine Parade Central
#11-03 Parkway Centre
Singapore 449408
Tel: +65-6346-5505
Fax: +65-6348-8096